

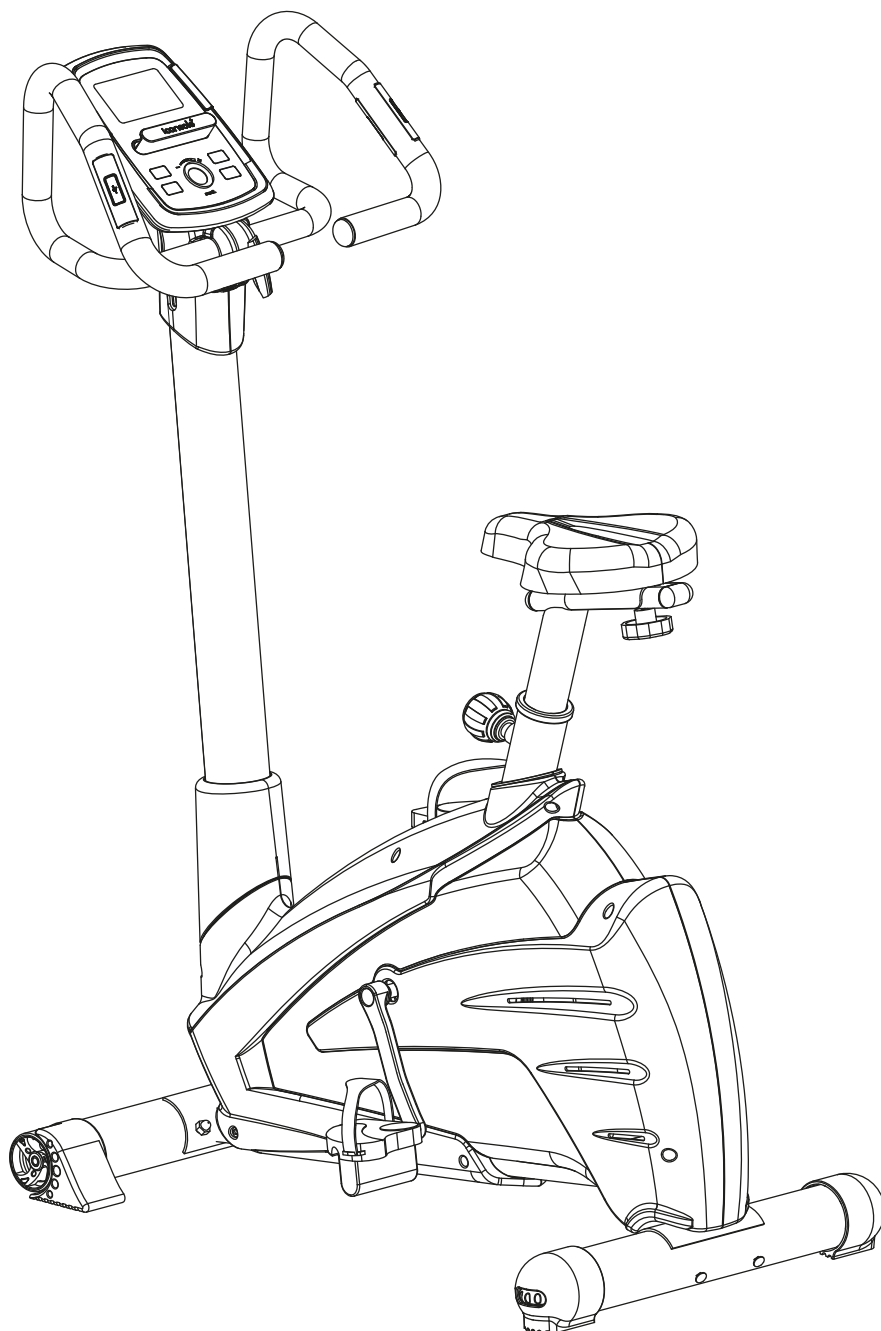

## Assembly and Operating Instructions



max. 130 kg



~ 60 Min. 



35 kg

L 90 | W 57 | H 140

CSTBX30PLUS.01.06

Art. No. CST-BX30-PLUS

Upright Bike **BX30 Plus**



# Content

<b>1</b>	<b>GENERAL INFORMATION</b>	<b>7</b>
1.1	Technical Data	7
1.2	Personal Safety	8
1.3	Electrical Safety	9
1.4	Set-Up Place	10
<b>2</b>	<b>ASSEMBLY</b>	<b>11</b>
2.1	General Instructions	11
2.2	Scope of Delivery	12
2.3	Assembly	14
<b>3</b>	<b>OPERATING INSTRUCTIONS</b>	<b>21</b>
3.1	Console Display	21
3.2	Button Functions	23
3.3	Turning On and Setting Up the Equipment	24
3.4	Energy Saving Mode	24
3.5	Programmes	25
3.5.1	Quick-Start	25
3.5.2	Manual Programme (M)	25
3.5.3	Pre-Set Profile Programmes	27
3.5.4	Heart Rate Controlled Programmes (♥)	28
3.5.5	Watt Controlled Programme (W)	29
3.5.6	User-Defined Programme (U)	30
3.6	Recovery	31
3.7	Body Fat Analysis	32
3.8	Compatibility Training Apps	33
3.8.1	Connection with Kinomap	33
<b>4</b>	<b>WORKOUT INSTRUCTIONS</b>	<b>35</b>
4.1	10 Tips for Effective Training	35
4.2	Training Schedule	36
4.3	Stretching Exercises for Leg and Chest Muscles	38
4.4	Workout Journal	40
4.5	Fitness Guide	41
<b>5</b>	<b>STORAGE AND TRANSPORT</b>	<b>42</b>
5.1	General Instructions	42
5.2	Transportation Wheels	42

<b>6</b>	<b>TROUBLESHOOTING, CARE AND MAINTENANCE</b>	<b>43</b>
6.1	General Instructions	43
6.2	Faults and Fault Diagnosis	43
6.3	Error Codes and Troubleshooting	44
6.4	Maintenance and Inspection Calendar	44
<b>7</b>	<b>DISPOSAL</b>	<b>45</b>
<b>8</b>	<b>RECOMMENDED ACCESSORIES</b>	<b>46</b>
<b>9</b>	<b>ORDERING SPARE PARTS</b>	<b>47</b>
9.1	Serial Number and Model Name	47
9.2	Parts List	49
9.3	Exploded Drawing	52
<b>10</b>	<b>WARRANTY</b>	<b>53</b>
<b>11</b>	<b>CONTACT</b>	<b>55</b>

**Dear customer,**

thank you for choosing fitness equipment from cardiostrong®. cardiostrong offers high-quality home fitness equipment that is optimally adapted to the conditions at home. Train at home no matter what the weather or time of the day. cardiostrong fitness equipment offers training programmes and a variety of equipment for all training levels and all training goals. We hope you enjoy your training!

Further information can be found at [www.sport-tiedje.com](http://www.sport-tiedje.com) or [www.cardiostrong.de](http://www.cardiostrong.de).

**Intended Use**

The equipment may only be used for its intended purpose.

The equipment is only suitable for home use (class H). The equipment is not suitable for semi-professional (e.g. hospitals, associations, hotels, schools, etc.) and commercial or professional use (e.g. fitness studios).

**Disclaimer**



©2010 cardiostrong® is a registered brand of the company SportTiedje GmbH. All rights reserved. Any use of this trademark without the explicit written permission of Sport-Tiedje is prohibited.

Product and manual are subject to change. Technical data can be changed without advance notice.

## ABOUT THIS MANUAL

Please carefully read the entire manual before installation and first use. The manual will help you to quickly set up the system and explains how to safely use it. Make sure that all persons exercising with the equipment (especially children and persons with physical, sensory, mental or motor disabilities) are informed about this manual and its contents in advance. In case of doubt, responsible persons must supervise the use of the equipment.



Due to ongoing changes and software optimisations, the manual may have to be updated. If you notice any discrepancies during assembly or use, please refer to the manual uploaded to the webshop. The latest manual is always available there.

This equipment has been manufactured according to the latest safety knowledge. As far as possible, potential safety hazards which could cause injury have been eliminated. Make sure to carefully follow the instructions and that all parts are securely in place. If required, read through the instructions again to correct any mistakes.

Please pay close attention to the safety and maintenance instructions given here. The contract partner cannot be held liable for damage to health, accidents or damage to the equipment when it is not used in accordance with these instructions.

The following safety instructions may appear in this manual:

► **ATTENTION**

This notice indicates potentially hazardous situations which, if not avoided, may result in property damage.

 **CAUTION**

This notice indicates potentially hazardous situations which, if not avoided, may result in slight or minor injuries!

 **WARNING**

This notice indicates potentially hazardous situations which, if not avoided, may result in death or serious injuries!

 **DANGER**

This notice indicates potentially hazardous situations which, if not avoided, will result in death or serious injuries!

 **NOTICE**

This notice indicates further useful information.

Retain these instructions in a safe place for future reference, maintenance or when ordering replacement parts.

## 1.1 Technical Data

### LCD Display:

- + Speed in km/h
- + Training time in min
- + Training distance in km
- + RPM (Revolutions per Minute)
- + Calories burned
- + Heart rate (in conjunction with using the hand pulse sensors or a chest strap)
- + Watts
- + Resistance level

Resistance system: electronic magnetic brake system  
(speed dependent, speed independent in  
the watt controlled programme)

Resistance level: 32

### Wattage

Min. and max. Wattage at 60 RPM: 21 - 270 Watts

Min. and max. Wattage at 100 RPM: 45 - 607 Watts

Adjustable range in the Watt programme: 10 - 350 Watts

Manual programmes: 1  
Pre-set programmes: 12  
Watt controlled programmes: 1  
Heart rate controlled programmes: 4  
User-defined programmes: 1 (per user)

Flywheel mass: 9 kg  
Pedal arm length: 17 cm  
Q-factor/pedal spacing: 21.4 cm  
Gear ratio: 1:8.25

### Weight and dimensions

Article weight (gross, including packaging): 41.28 kg  
Article weight (net, without packaging): 35.2 kg

Packaging dimensions (L x W x H) approx.: 98 cm x 73 cm x 31 cm  
Set-up dimensions (L x W x H) approx.: 90 cm x 57 cm x 140 cm  
Maximum user weight: 130 kg (286 lbs)

## 1.2 Personal Safety

### **DANGER**

- + Before you start using the equipment, you should consult your physician that this type of exercise is suitable for you from a health perspective. Particularly affected are persons who: have a hereditary disposition to high blood pressure or heart disease, are over the age of 45, smoke, have high cholesterol values, are overweight and/or have not exercised regularly in the past year. If you are under medical treatment that affects your heart rate, medical advice is absolutely essential.
- + Note that excessive training can seriously endanger your health. Please also note that heart rate monitoring systems can be inaccurate. If you notice any signs of weakness, nausea, dizziness, pain, shortness of breath, or other abnormal symptoms, stop exercising immediately and seek advice from your doctor if necessary.
- + Always start your training with low intensity and increase evenly and gently. End your training with a cool-down phase. If you are unsure, please consult your physician.

### **WARNING**

- + This equipment may not be used by children under the age of 14.
- + Children should not be allowed unsupervised access to the equipment.
- + Persons with disabilities must have a medical license and must be under strict observation when using the equipment.
- + The equipment is strictly for use by one person at a time.
- + If your equipment provides a safety key, the clip of the safety key must be attached to your clothing before starting your training. In the event of a fall, the EMERGENCY STOP of the equipment can be initiated.
- + Keep your hands, feet and other body parts, hair, clothing, jewellery and other objects well clear of moving parts.
- + During use, wear suitable sports clothing rather than loose or baggy clothing. When wearing sports shoes, make sure they have suitable soles, preferably made of rubber or other non-slip materials. Shoes with heels, leather soles, studs or spikes are unsuitable. Never exercise barefoot.
- + Support yourself with at least one hand on the handlebar when getting on and off the equipment. Only dismount from the equipment when the pedals have come to a complete stop.

### **CAUTION**

- + If your equipment needs to be connected to the power supply with a mains cable, make sure that the cable is not a potential tripping hazard.
- + Make sure that nobody is within the range of motion of the equipment during training so as not to endanger you or other persons.
- + Be aware that if adjustment devices are left protruding, they may impede the user's movement.

### **ATTENTION**

- + Do not insert any objects of any kind into the openings of the device.



## 1.3 Electrical Safety

### **DANGER**

- + In order to reduce the risk of an electric shock, always unplug the equipment from the mains socket immediately after your workout, before assembly or dismantling, and before maintenance or cleaning. Do not pull on the cable.

### **WARNING**

- + Do not leave the equipment unattended while the mains cable is plugged into the mains socket. During your absence, the mains cable must be removed to prevent improper use by third parties or children.
- + If the mains cable or plug is damaged or defective, contact your contract partner. In the meantime, the equipment must not be used.

### **ATTENTION**

- + The equipment requires a mains connection of 220-230 V with 50 Hz mains voltage.
- + The equipment may only be connected directly to an earthed socket using the supplied mains cable. Extension cables must conform to VDE guidelines. Always completely unwind the mains cable.
- + The socket must be protected by a fuse with a minimum fuse rating of "16 A, slow blow".
- + Do not make any changes to the mains cable or the mains plug.
- + Keep the mains cable away from water, heat, oil and sharp edges. Do not route the mains cable underneath the equipment or under a carpet or rug, and do not place any objects on top of it.
- + If your purchased item is equipped with a TFT console, software updates must be carried out regularly. Follow the instructions on the console to perform the update(s).
- + The software systems on gym equipment with TFT consoles are set up only for the pre-installed apps. Do not install any additional apps.

### **NOTICE**

- + The pre-installed apps on TFT consoles are produced and provided by external manufacturers. Sport-Tiedje does not take any responsibility for the availability, functionality or contents of these apps.

## 1.4 Set-Up Place



### WARNING

- + Do not place the equipment in main corridors or escape routes.



### CAUTION

- + The training room should be well ventilated during training and not be exposed to any draughts.
- + Choose the place in which to set up the equipment such that there is enough free space/clearance to the front, the rear and to the sides of the equipment.
- + The free area in the direction from which the exercise equipment is accessed must be at least 0.6 m larger than the exercise area.
- + The set-up and mounting surface of the equipment should be flat, loadable and solid.

### ATTENTION

- + The device may only be used in one building, in sufficiently tempered and dry rooms (ambient temperatures between 10°C and 35°C). The equipment should not be used outdoors or in rooms with high humidity (over 70%) like swimming pools.
- + A floor protective mat/equipment underlay can help to protect high-quality floor coverings (parquet, laminate, cork, carpets) from dents and sweat and can help to level out slight unevenness.

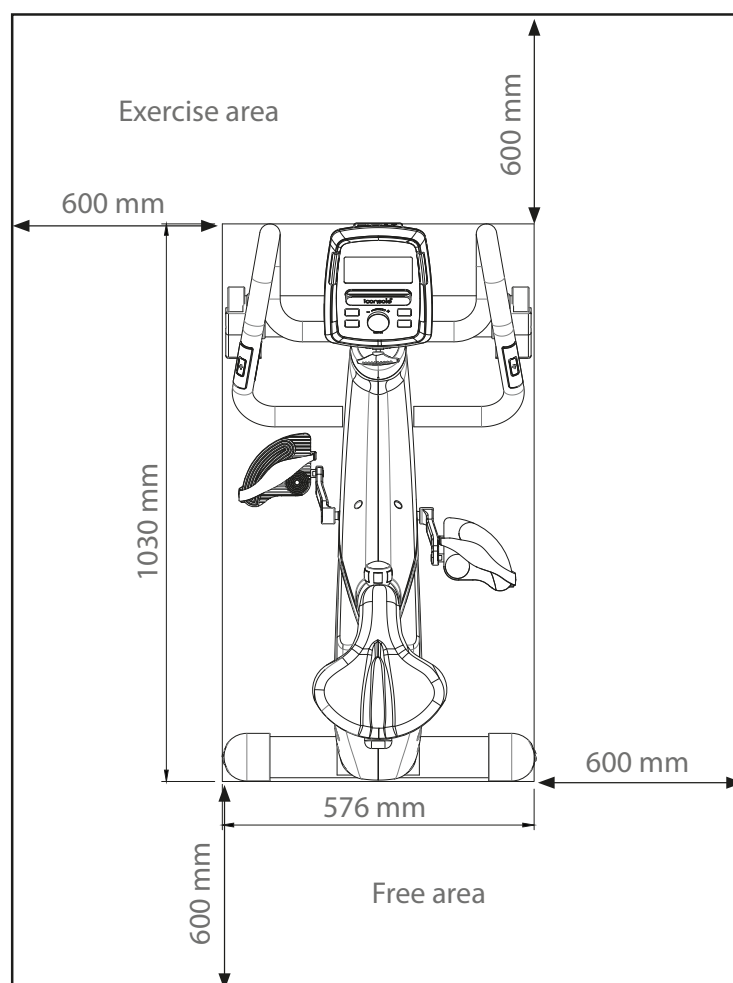

### 2.1 General Instructions



#### **DANGER**

- + Do not leave any tools, packaging materials such as foils or small parts lying around, as otherwise there is a danger of suffocation for children. Keep children away from the equipment during assembly.



#### **WARNING**

- + Pay attention to the instructions attached to the equipment in order to reduce the risk of injuries.



#### **CAUTION**

- + Do not open the packaging when it is lying on its side.
- + Ensure to have sufficient room for movement in each direction during assembly.
- + The assembly of the equipment must be carried out by at least two adults. If in doubt, seek the help of another technically skilled person.

#### **ATTENTION**

- + To prevent damage to the equipment and the floor, assemble the equipment on a mat or packaging board.



#### **NOTICE**

- + This equipment is classified as HA and is therefore approved for home use and has a high accuracy.
- + In order to make the assembly as simple as possible, some screws and nuts to be used can already be pre-assembled.
- + Ideally, assemble the equipment at its later set-up place.

## 2.2 Scope of Delivery

The scope of delivery consist of the following parts. At the beginning, check whether all parts and tools belonging to the device are included in the scope of delivery and whether damage has occurred. In the event of complaints, the contractual partner must be contacted directly.



### CAUTION

If parts of the scope of delivery are missing or damaged, the assembly must not be carried out.

<b>Parts number</b>	<b>Name</b>
1	Main frame
2	Rear stabilizer
3	Front stabilizer
9	Seat post
10 & 11	Seat and adjustable seat tube
15	Adapter
28	Upper protective cover
29	Handlebar post
36	Handlebar
38	Computer
41L & 41R	Left computer bracket and right computer bracket
46L & 46R	Left pedal and right pedal
	Montagesatz

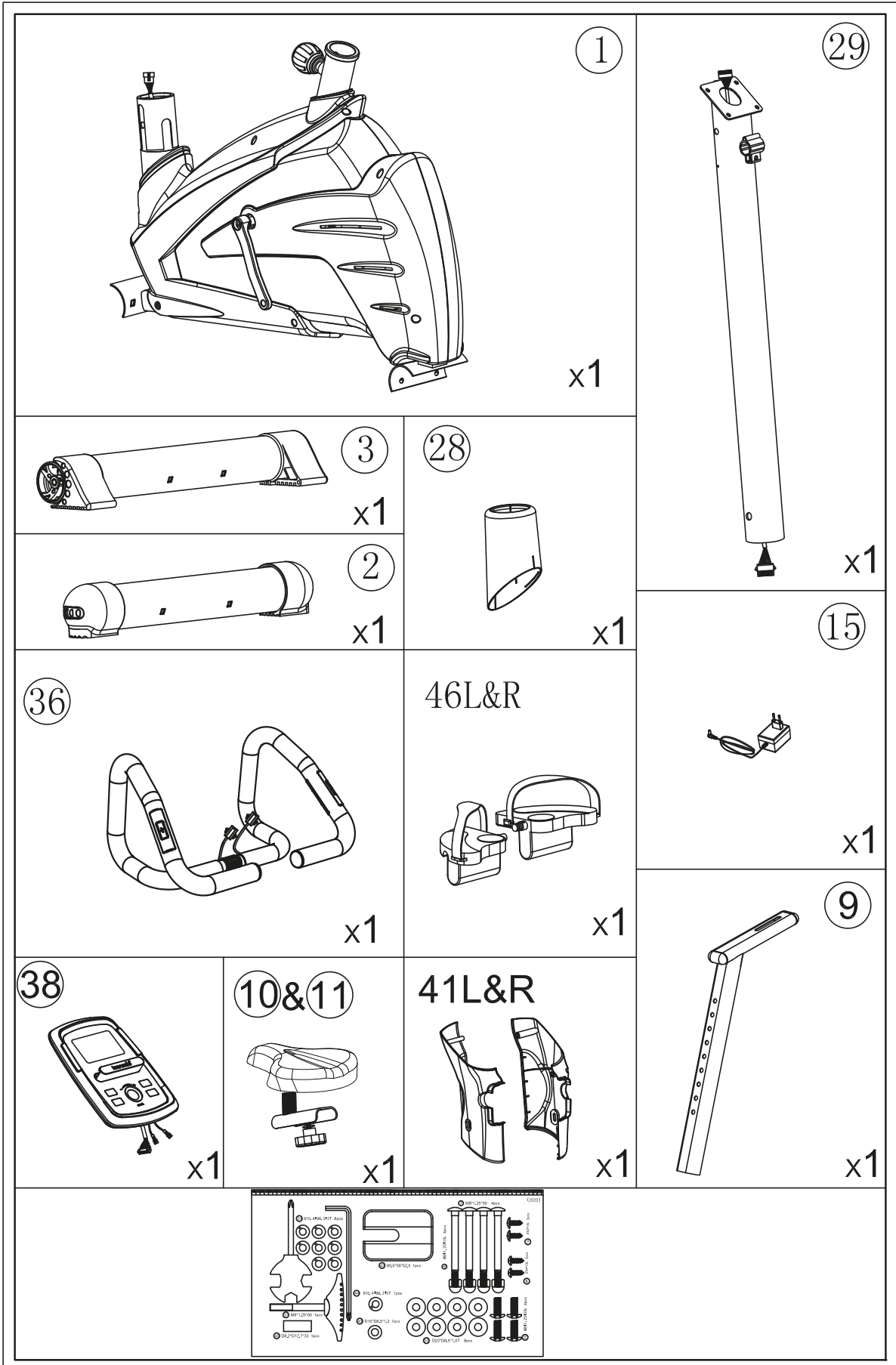

## 2.3 Assembly

Before assembly, take a close look at the individual assembly steps shown and carry out the assembly in the order given.

### ① NOTICE

- + First loosely screw all parts together and check that they fit properly. Tighten the screws using the tool only when you are instructed to do so.
- + If you have difficulty recognising the graphics, we recommend that you open and/or download the PDF instructions stored in the webshop on your end device (e.g. smartphone, tablet or PC). There you have the option of zooming in closer. Please note that the Adobe Acrobat Reader programme must be installed on your end device in order to open the file.

### Step 1: Assembly of the Front and Rear Stabilizers

Attach the front and rear stabilizer (3 & 2) to the main frame (1) with two screws (7), two washers (53), two spring washers (51) and two nuts (6) each.

### ① NOTICE

If the equipment is wobbly after assembly, you can adjust the height on the underside of the rear stabilizer.

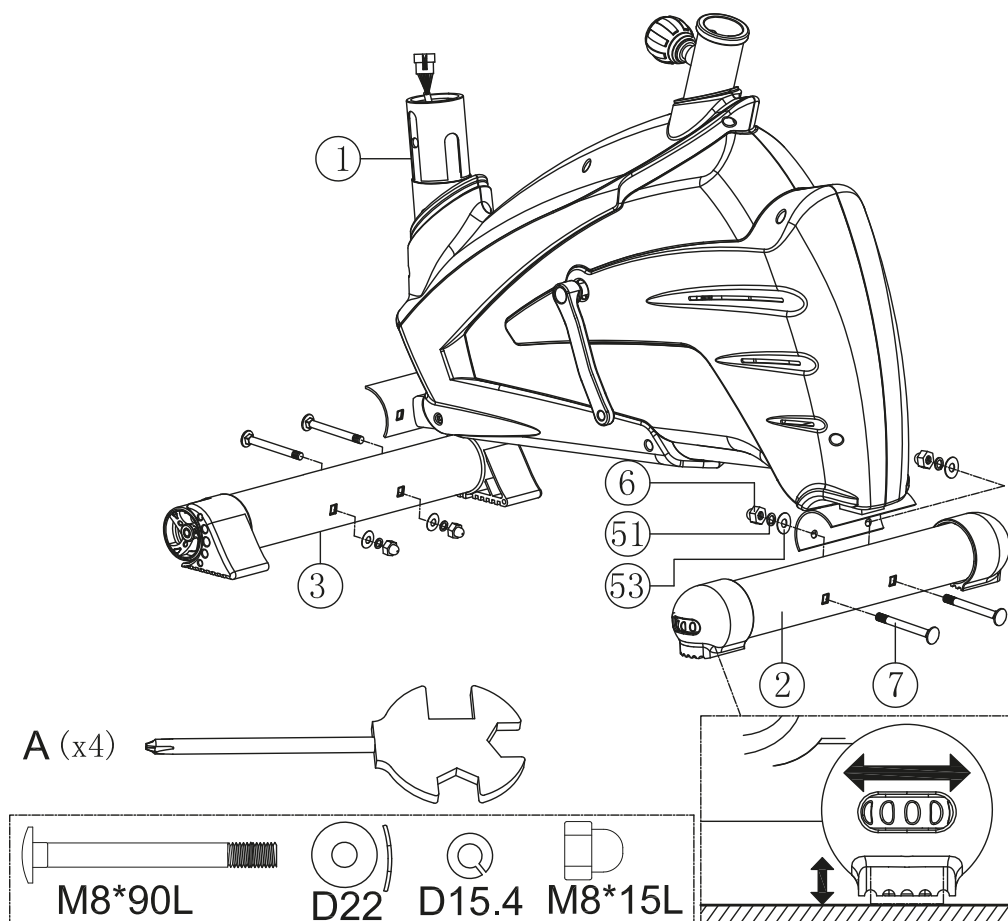

## Step 2: Assembly of the Seat

1. Attach the adjustable seat tube (11) to the seat post (9) with the screw knob (17) and flat washer (18).
2. Insert the seat post (9) into the main frame (1) and fix it with the ball knob (31).

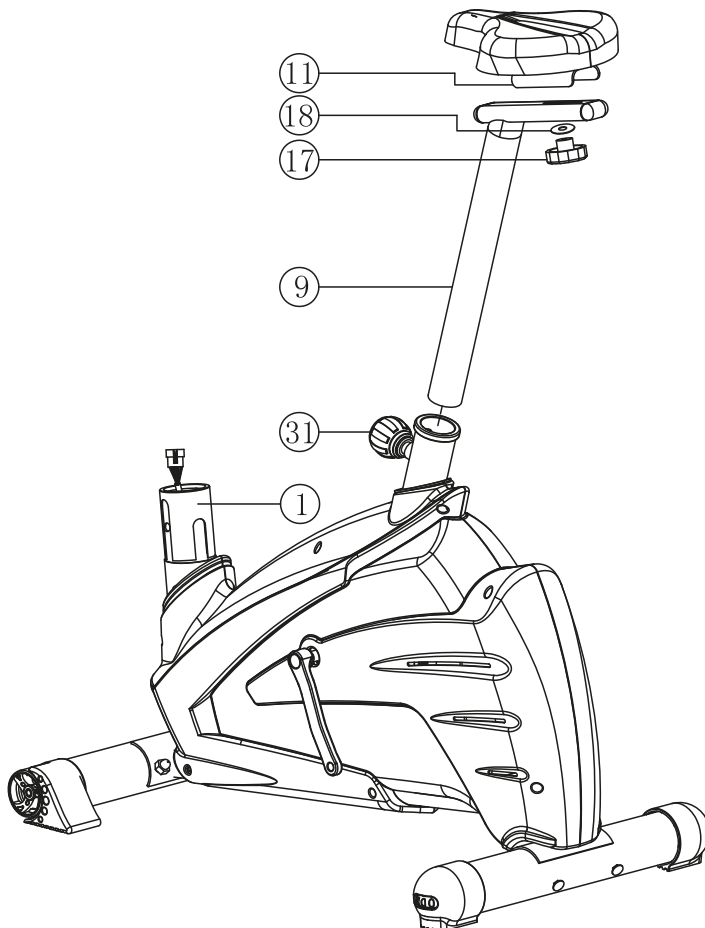
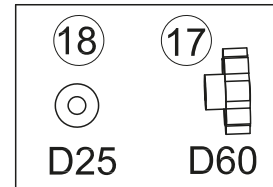
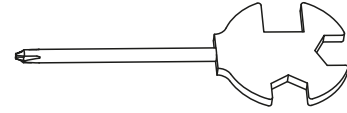

### Step 3: Assembly of the Handlebar Post

1. Slide the upper protective cover (28) onto the handlebar post (29); see figure a.
  2. Connect the upper console cable (39) with the lower console cable (40); see figure b.
- **ATTENTNION**  
Make sure to not pinch the cables during the next step.
3. Attach the handlebar post (29) to the main frame (1) with four screws (20), four washers (53) and four spring washers (51).

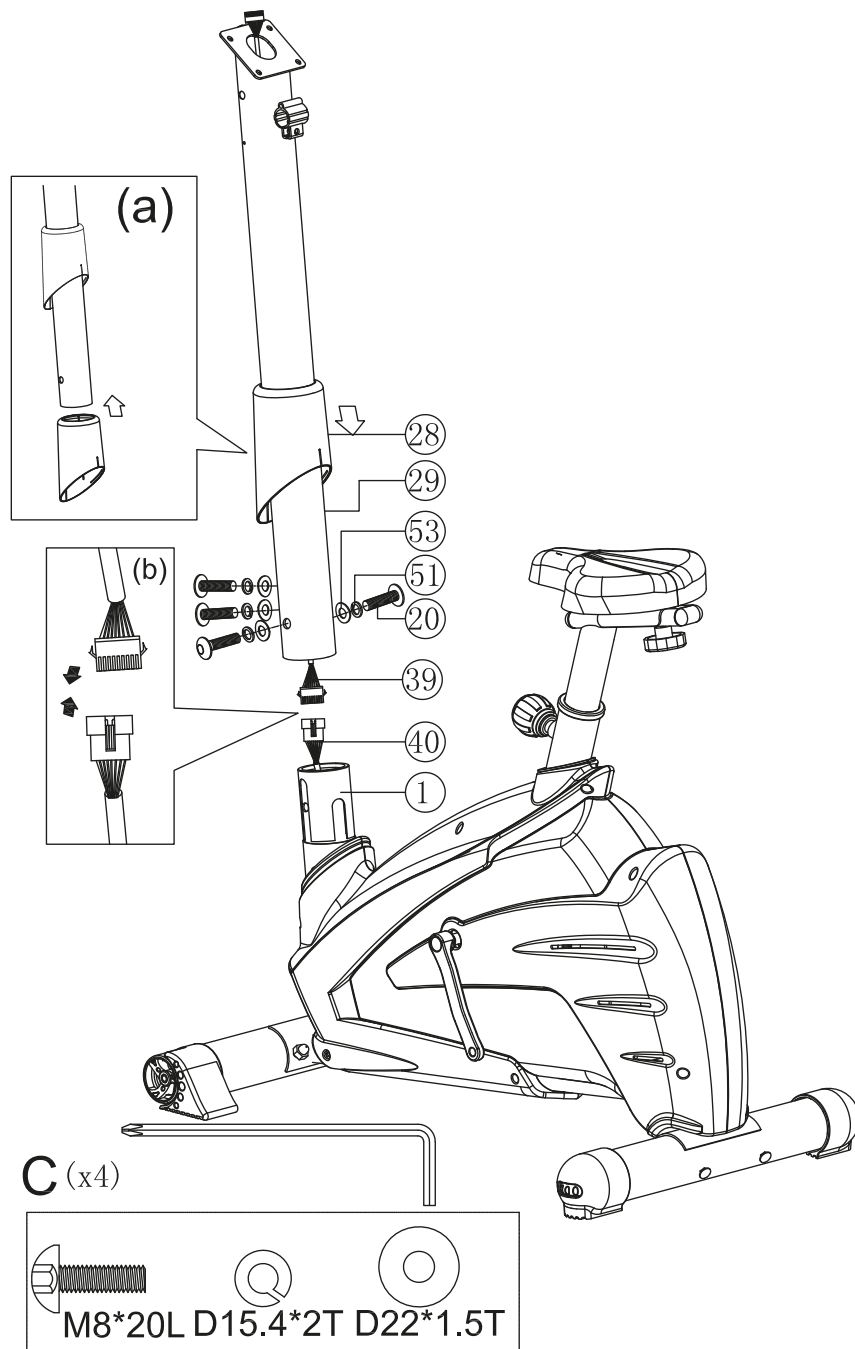



## Step 4: Assembly of the Handlebar

1. Attach the handlebar (36) to the handlebar post (29) by attaching the cover (42), washer (43), spring washer (44), connector (45) and the T-shaped knob (37).
2. Connect the upper computer cable (39) and the hand pulse cable (30) with their counterparts of the computer (38).

► **ATTENTION**

Make sure to not pinch the cables during the next step.

3. Attach the computer (38) to the handlebar post (29) with four screws (59).

ⓘ **NOTICE**

The position of the handlebar can be adjusted by using the T-shaped knob (37).

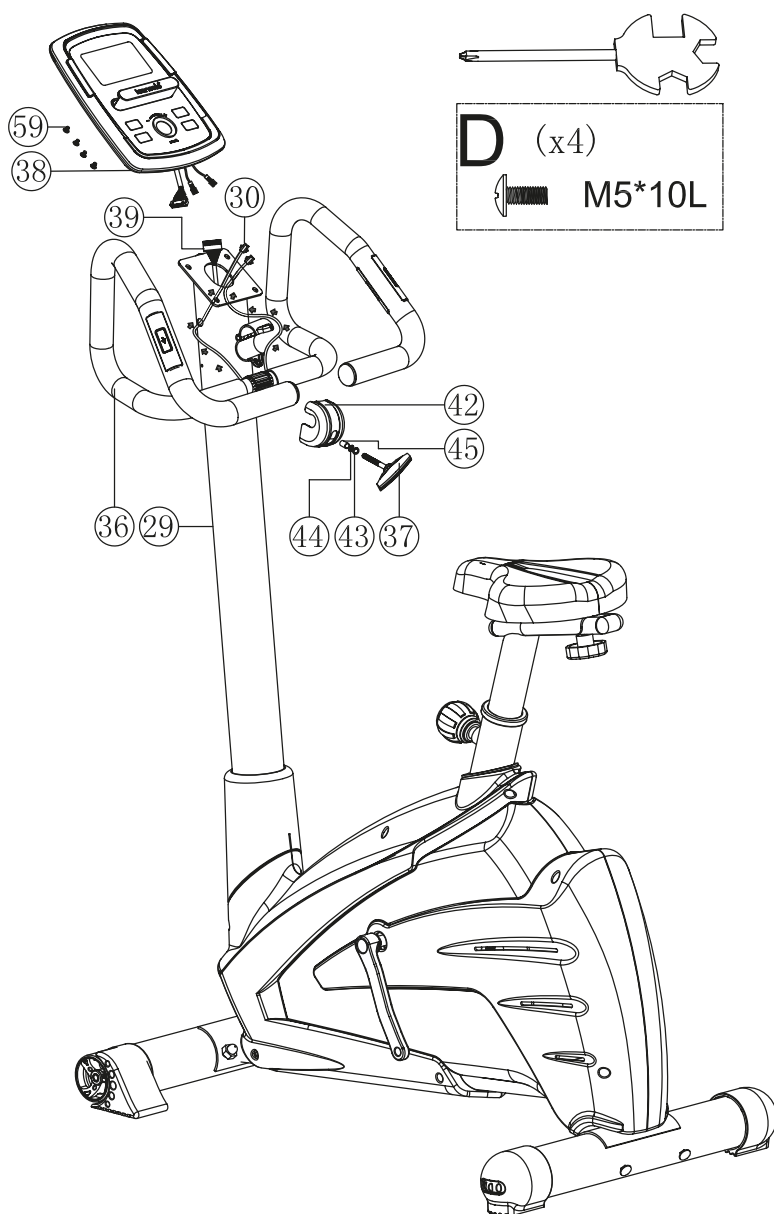

## Step 5: Assembly of the Computer Brackets and Pedals

1. Attach the left and right computer brackets (41L & 41R) to the handlebar post (29) with the screws (69) and (14).



### CAUTION

Make sure to screw in the pedals completely.

2. Attach the pedal straps to the left and right pedals (46L & 46R).
3. Attach the left and right pedals (46L & 46R) to the cranks. Turn the left pedal counterclockwise and the right pedal clockwise.

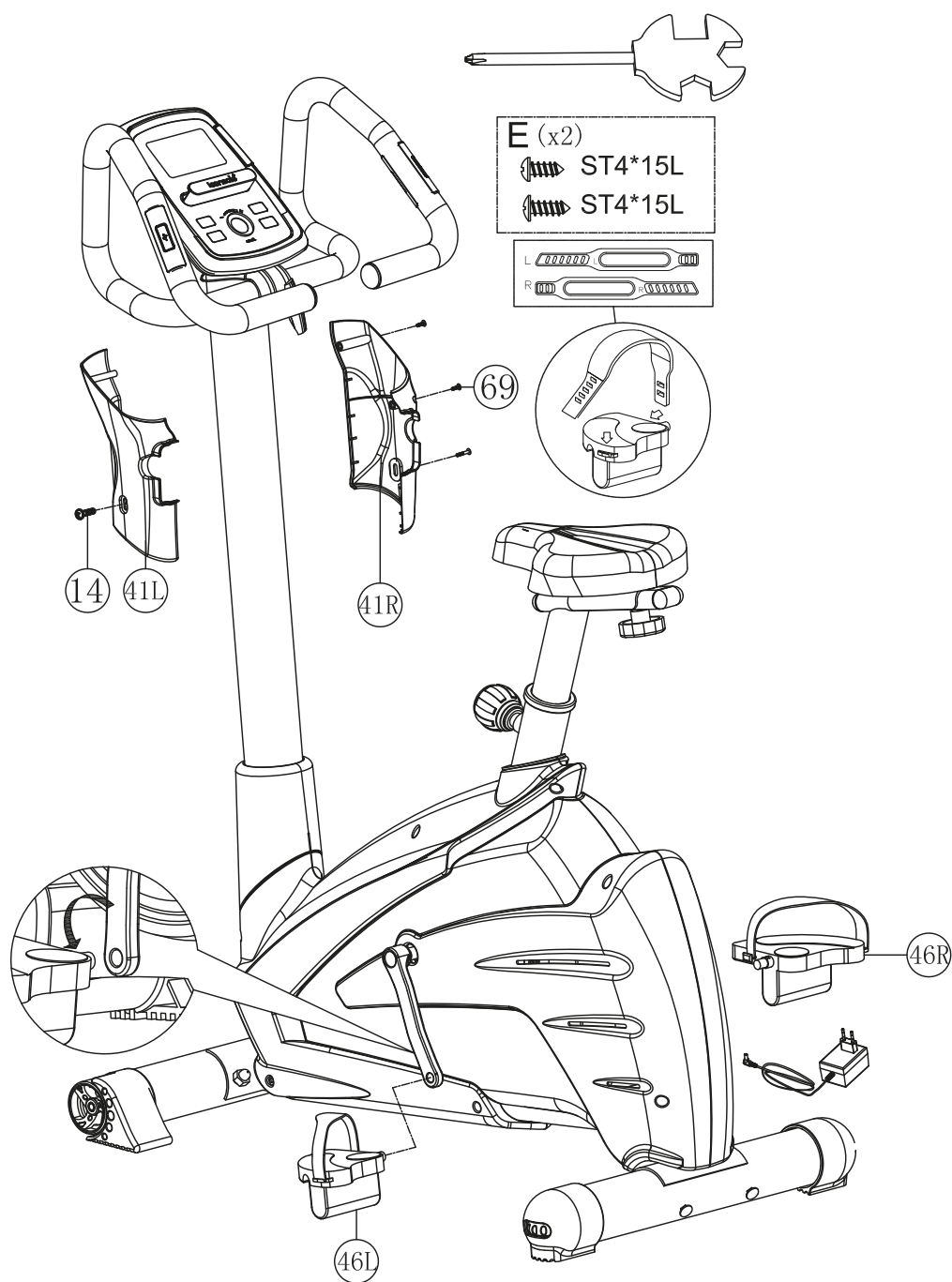

## Step 6: Adjusting the Seat Position

### CAUTION

The seat post is marked with "STOP" for the minimum insertion depth. When adjusting, make sure not to exceed the minimum insertion depth.

### Height Adjustment:

1. Loosen the knob (31) and pull it out in order to adjust the height of the seat post.

### CAUTION

In the following step, make sure that the knob audibly engages in one of the adjustment holes.

2. Release the knob.
3. Tighten the knob again.

### Horizontal Adjustment:

1. Turn the knob (17) under the seat until you can move the seat forwards and backwards.
2. Move the seat into the desired position and tighten the knob again.

### Tilt Adjustment:

1. Loosen the nuts underneath the seat until the seat tilt can be adjusted.
2. Adjust the desired tilt and tighten the nuts again.

## Step 7: Adjusting the Handlebar Position

Rotate the lever (37) on the front of the handle until you can adjust the tilt of the handle. Once the handle is in the desired position, tighten the lever again.

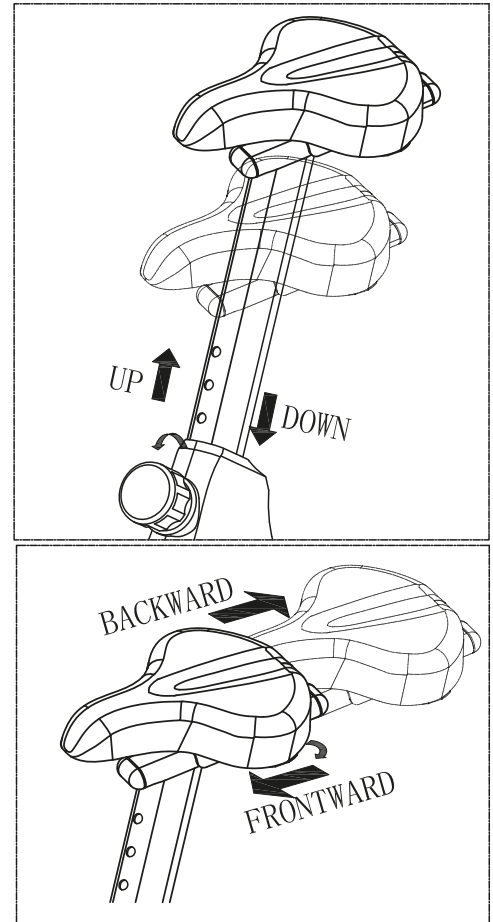

## Correct Sitting Position:

For a correct posture and to avoid malpositions and/or injuries, we recommend to read our article "the correct posture on the ergometer" on our fitness blog which you can access using the QR code provided.



### **CAUTION**

If you are unsure or have questions, please consult your physician.

### **NOTICE**

The blog article is currently available in German language.

## Step 8: Adjusting the Pedal Straps

### **NOTICE**

The strap should rest loosely over the ball of the foot and not sit firmly under any circumstances. Loosen the strap on the underside of the pedal and adjust it so that the strap fits comfortably.

## Step 8: Connecting the Equipment to the Mains Supply

### **ATTENTION**

The equipment must not be connected to a multiple socket, otherwise it cannot be guaranteed that the equipment will be supplied with sufficient power. Technical errors can result.

1. Connect the adapter (15) to the fitness equipment.
2. Plug the power plug into a wall outlet that complies with the instructions in the chapter on electrical safety.

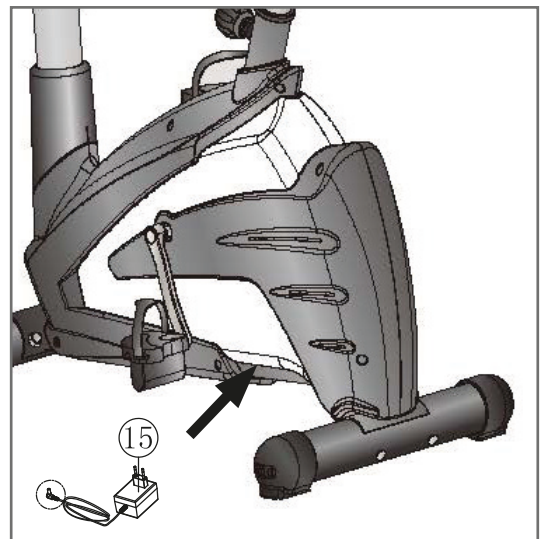

## 3 OPERATING INSTRUCTIONS



### ① NOTICE

Familiarise yourself with all the functions and setting options of the device before starting training. Have the proper use of this product explained to you by a specialist.

### 3.1 Console Display



<b>TIME</b>	<ul style="list-style-type: none"><li>+ Display of the elapsed training time in minutes</li><li>+ Display range: 00:00 - 99:59</li><li>+ Setting range: 00:00 - 99:00 (in 01:00 min. increments)</li></ul>
<b>SPEED</b>	<ul style="list-style-type: none"><li>+ Display of the current speed in km/h</li><li>+ Display range: 00.0 - 99.9</li></ul>
<b>RPM</b>	<ul style="list-style-type: none"><li>+ Display of the current revolutions per minute (RPM)</li><li>+ Display range: 0 - 999</li></ul>
<b>DISTANCE</b>	<ul style="list-style-type: none"><li>+ Display of the training distance in km</li><li>+ Display range: 0.00 - 99.99</li><li>+ Setting range: 0.00 - 99.99 (in 0.1km increments)</li></ul>

<b>CALORIES</b>	<ul style="list-style-type: none"> <li>+ Display of calories burned in kcal</li> <li>+ Display range: 0 - 9999</li> </ul> <p>ⓘ <b>NOTICE</b> These data serve as a rough guide for comparing your training sessions, they cannot be used for medical purposes.</p>
<b>PULSE</b>	<ul style="list-style-type: none"> <li>+ Display of your current heart rate</li> <li>+ Display range: 0 - 230</li> <li>+ Setting range: 30 - 230</li> </ul>
<b>WATT</b>	<ul style="list-style-type: none"> <li>+ Display of the Watt value</li> <li>+ Display range: 0 - 999</li> <li>+ Setting range in the Watt programme: 10-350</li> </ul>
<b>M</b>	+ Manual programme
	+ 12 pre-set profile programmes
	+ Heart rate controlled programmes
<b>W</b>	+ Watt controlled programme
<b>U</b>	+ User defined programme

## 3.2 Button Functions

The console is equipped with a total of five buttons, of which the jog dial functions as the central and intuitive operating element. This allows you to quickly select and confirm all values. By simply turning to the left or to the right, you can select between programmes, set or adjust training values. By pressing the jog dial (Mode), you confirm the respective selection or entry.

<b>Jog dial (+)</b>	<ul style="list-style-type: none"><li>+ Turn to the right to increase resistance level</li><li>+ Turn to the right to increase value</li><li>+ Choose programme</li></ul>
<b>Jog dial (-)</b>	<ul style="list-style-type: none"><li>+ Turn left to decrease resistance level</li><li>+ Turn left to decrease value</li><li>+ Choose programme</li></ul>
<b>Mode (jog dial)</b>	<ul style="list-style-type: none"><li>+ Press the jog dial shortly to confirm entry or selection choice</li></ul>
<b>Reset</b>	<ul style="list-style-type: none"><li>+ Press and hold the button for two seconds to restart the console and to begin with the user entry.</li><li>+ A quick press during a paused programme or while entering training values results in returning to the main menu</li></ul>
<b>Start/Stop</b>	<ul style="list-style-type: none"><li>+ Press to start or pause training</li></ul>
<b>Recovery</b>	<ul style="list-style-type: none"><li>+ Press to start the heart rate recovery test</li></ul>
<b>Body fat</b>	<ul style="list-style-type: none"><li>+ Press to start the body fat analysis</li></ul>

### 3.3 Turning On and Setting Up the Equipment

1. Insert the power cord plug into the wall socket.

The console turns on and shows all segments of the LCD display for two seconds. (Fig. 1).

1. Choose a user profile (U1 - U4) using the jog dial.
2. Enter your gender, age, height and weight (Fig. 2) and confirm each value with the Mode button.

Once you have entered your user data, the main menu will be displayed (Fig. 3).

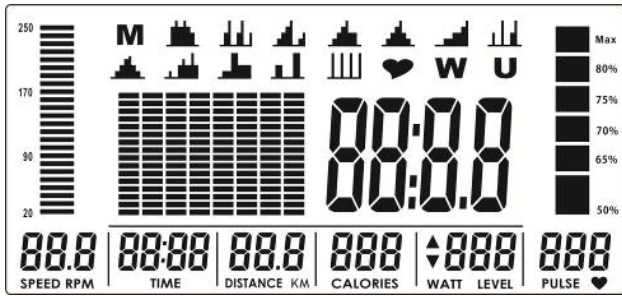

Figure 1

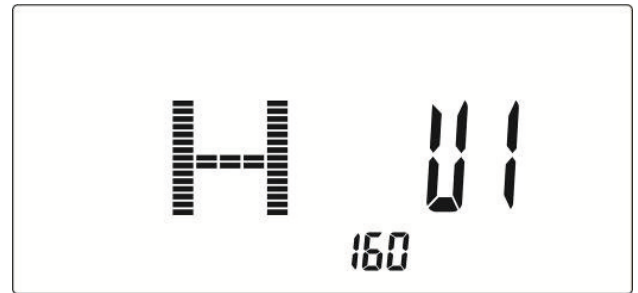

Figure 2

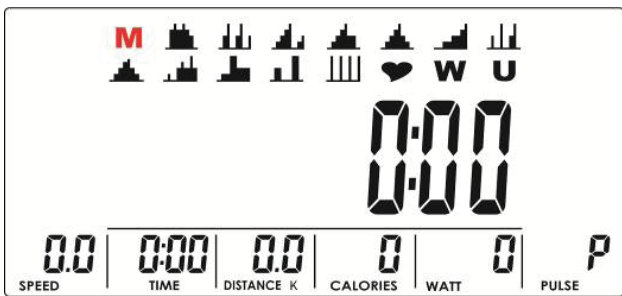

Figure 3

### 3.4 Energy Saving Mode

The console goes into energy saving mode when the pedals have not moved or no pulse can be read for four minutes. Press any button to start the console again.

#### ① NOTICE

Should the console not react, disconnect and re-insert the power cord.



## 3.5 Programmes

There is a total of 19 programmes available to choose from:

- + Manual programmes: 1
- + Pre-set programme: 12
- + Heart rate controlled programmes: 4
- + Watt controlled programmes: 1
- + User-defined programmes: 1 (per user)
- + Quick-start

Use the jog dial to choose a programme: M (manual programme) → Pre-set programmes 1–12 → ♥ (Heart rate programmes) → W (Watt controlled programme) → U (User defined programme) and confirm your choice with the Mode button.

### 3.5.1 Quick-Start

The so-called quick-start function is the ideal choice if you simply want to work out immediately without entering any training data.

1. To start the quick-start function directly from the main menu, press the Start/Stop button.

*The training starts.*

*All values will start counting upwards.*

#### **NOTICE**

The resistance level can be adjusted with the jog dial during training.

2. To pause the training, press the Start/Stop button during training.
3. To resume the training, press the Start/Stop button again.
4. To end the training, press the Reset button.

*The display returns to the main menu.*

### 3.5.2 Manual Programme (M)

#### **WARNING**

This equipment is not a medical equipment. The heart rate measurement of the equipment can be unprecise. Different factors can influence the heart rate reading. The heart rate readings are only meant as a guide for training.

In the manual programme, you can set the values for time, distance, calories and/or heart rate. You can decide if you want to train with a singular or multiple target values.

#### **NOTICE**

If you enter a heart rate value, you must grab the hand pulse sensors on the handlebar with both hands during training or wear a compatible chest strap.

1. Choose manual programme (M) and confirm your choice with the Mode button.

#### **NOTICE**

To skip setting a certain value, press the Mode button.

2. Set the resistance level with the jog dial and confirm with the Mode button (Fig. 4).
3. Set a value for time, distance, calories and/or heart rate with the jog dial and confirm each value with the Mode button (Fig. 5 - 8).
4. To start the programme, press the Start/Stop button.

*The programme starts.*

*Set target values will count down and the remaining values will count upwards (Fig. 9).*

*As soon as the first set target value is reached, a signal will sound.*

**NOTICE**

The resistance level can be adjusted with the jog dial during training.

5. To pause the programme, press the Start/Stop button during training.
6. To resume the programme, press the Start/Stop button again.
7. To end the programme, press the Reset button.

*The display returns to the main menu.*

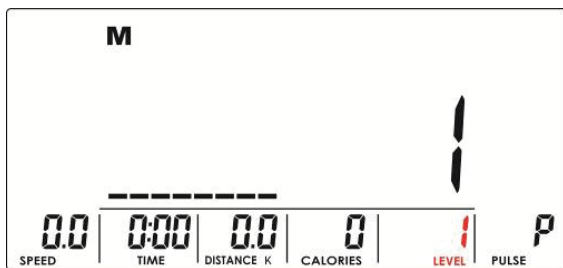

Figure 4

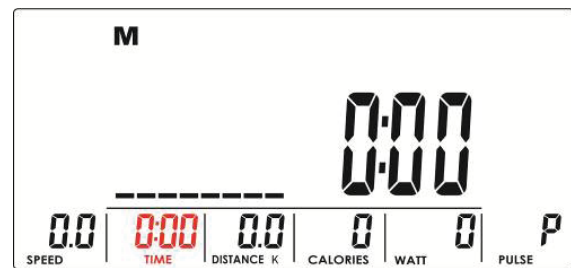

Figure 5

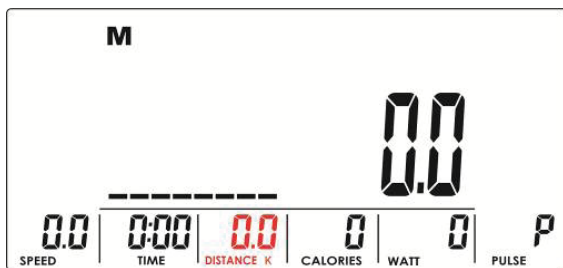

Figure 6

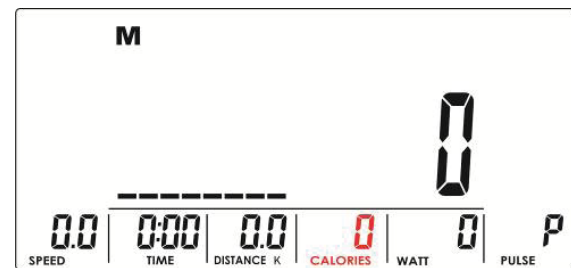

Figure 7

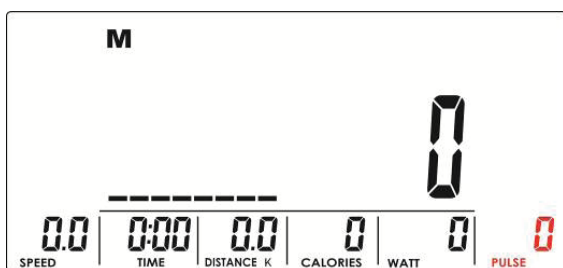

Figure 8

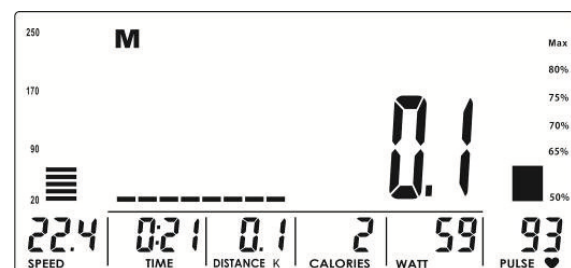

Figure 9

### 3.5.3 Pre-Set Profile Programmes

There are a total of 12 pre-set programmes available. Each programme consists of eight segments in which the resistance level is pre-set differently. This allows you to bring more variety into your workouts.

1. Choose one of the pre-set programmes and confirm your choice with the Mode button.

**NOTICE**

- + You can optionally increase the base resistance of all segments of the selected profile programme. In that case, the resistance for each segment is increased according to the selected resistance level. The default value is 1 (Fig. 10).
  - + If you do not change the base resistance, the profile programme is adapted as pre-set.
2. If desired, adjust the base resistance with the jog dial and confirm with the Mode button.
    - 2.1. To adopt the profile programme as pre-set, press the mode button.
  3. Set the training time with the jog dial and confirm with the Mode button.
    - 3.1. If you do not wish to set a training time, press the Mode button once more after you have set the resistance level.

**NOTICE**

- + When you set a training time, the duration of each segment is calculated by dividing the training time by 8. For example, if you enter a training time of 8 minutes, the duration of a segment is 1 minute until the console switches to the next segment. If you enter 24 minutes, the duration of each segment is 3 minutes.
  - + If you do not set a training time, the console switches to the next segment every 100 metres. This will continue repetitively until you actively end the programme.
4. To start the programme, press the Start/Stop button.

*The programme starts.*

**NOTICE**

The resistance level can be adjusted with the jog dial during training.

*At the end of the programme, a signal will sound.*

5. To pause the programme, press the Start/Stop button during training.
6. To resume the programme, press the Start/Stop button again.
7. To end the programme, press the Reset button.

*The display will change to the main menu.*

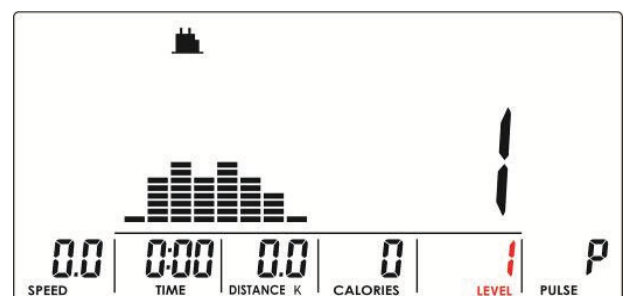

Figure 10

### 3.5.4 Heart Rate Controlled Programmes (♥)

**⚠ WARNING**

This equipment is not a medical equipment. The heart rate measurement of the equipment can be unprecise. Different factors can influence the heart rate reading. The heart rate readings are only meant as a guide for training.

**📌 NOTICE**

During training in the heart rate controlled programmes, you must always keep both hands on the hand pulse sensors or wear a compatible chest strap.

There are four heart rate programmes available to choose from. You can choose from three pre-set heart rate targets (55%, 75% or 90% of your maximum heart rate) or TA (Target heart rate) and manually set a different value. Your maximum heart rate is calculated by the console and depends on the set age in the user profile.

1. Choose the heart rate programme (♥) and confirm your choice with the Mode button.
2. Choose the desired heart rate programme (55%, 75%, 90% or TA) with the jog dial and confirm your choice with the Mode button (Fig. 11 - 14).
- 2.1. If you chose the target heart rate (TA), now set your desired heart rate (30 - 230) with the jog dial and confirm with the Mode button.
3. Set the training time with the jog dial and confirm with the Mode button.
4. To start the programme, press the Start/Stop button.

*The programme starts.*

*If your current heart rate exceeds the set heart rate, a signal will sound. Reduce your training speed.*

5. To pause the programme, press the Start/Stop button during training.

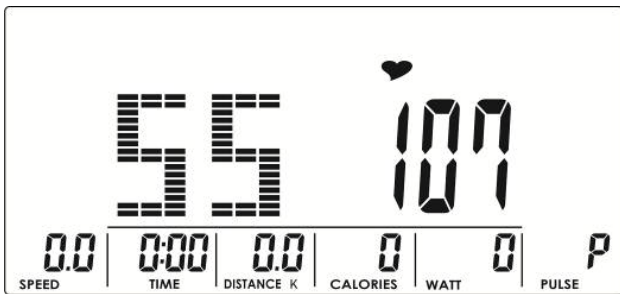

Figure 11

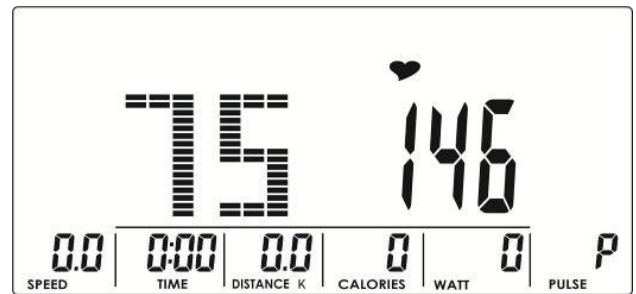

Figure 12

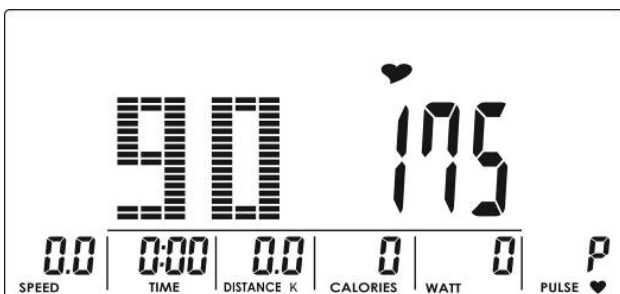

Figure 13

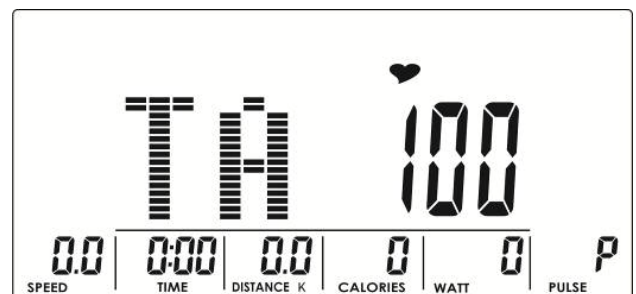

Figure 14

6. To resume the programme, press the Start/Stop button again.
7. To end the programme, press the Reset button.

*The display returns to the main menu.*

### 3.5.5 Watt Controlled Programme (W)

The watt controlled programme allows you to train in a targeted and performance-oriented way, as you set the specified power as a watt value yourself. This means that the power output is always the same.

1. Choose the Watt controlled programme (W) and confirm with the Mode button.
2. Set a Watt value with the jog dial and confirm with the Mode button.

**① NOTICE**

The default value is 120 (Fig. 15)

3. Set the training time with the jog dial and confirm with the Mode button.
4. To start the programme, press the Start/Stop button.

*The programme starts.*

**① NOTICE**

- + The resistance level will automatically be adapted to the set Watt value and cannot be adjusted.
- + The Watt value can be adjusted with jog dial during training.

*At the end of the programme, a signal will sound.*

5. To pause the programme, press the Start/Stop button during training.
6. To resume the programme, press the Start/Stop button again.
7. To end the programme, press the Reset button.

*The display returns to the main menu.*

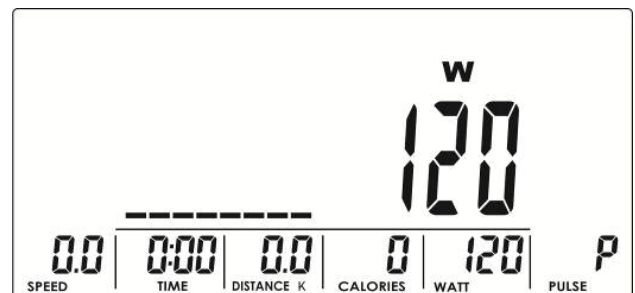

Figure 15

### 3.5.6 User-Defined Programme (U)

For each user profile there is one user-defined programme with eight segments available to set. The user-defined programme is similar to the pre-set profile programme with the exception that you set the resistance for each of the segments yourself.

1. Choose the user-defined programme (U) and confirm with the Mode button.
2. Set the resistance level for each segment with the jog dial and confirm each segment with the Mode button (Fig. 16).
3. To start the programme without setting a training time, press the Start/Stop button.
- 3.1. To set a training time, press and hold the Mode button for approximately 3 seconds until the selection switches to the time setting.
- 3.2. Set the training time with the jog dial and confirm with the Mode button.

**ⓘ NOTICE**

- + When you set a training time, the duration of each segment is calculated by dividing the training time by 8. For example, if you enter a training time of 8 minutes, the duration of a segment is 1 minute until the console switches to the next segment. If you enter 24 minutes, the duration of each segment is 3 minutes.
- + If you do not set a training time, the console switches to the next segment every 100 metres. This will continue repetitively until you actively end the programme.

4. To start the programme, press the Start/Stop button.

**ⓘ NOTICE**

The resistance level can be changed with the jog dial during training.

*The programme starts.*

*At the end of the programme, a signal will sound.*

5. To pause the programme, press the Start/Stop button during training.
6. To resume the programme, press the Start/Stop button again.
7. To end the programme, press the Reset button.

*The display returns to the main menu.*

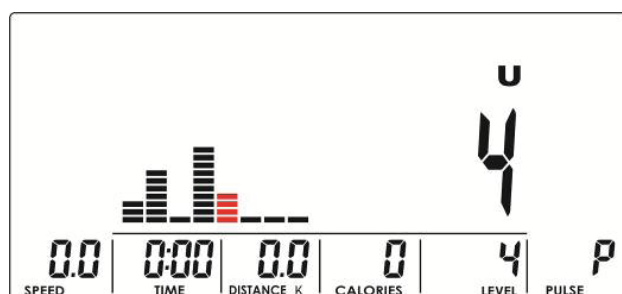

Figure 16

### 3.6 Recovery

The recovery function measures your heart recovery rate after a training session. A fitness score is calculated based on how quickly your heart rate recovers within 60 seconds. This allows you to document your fitness level and better understand your training achievements.

1. In the paused programme or after a completed training session, press the Recovery button and hold onto the hand pulse sensors with both hands or wear a compatible strap.

**NOTICE**

- + Keep your hands on the hand pulse sensors at all times during the 60 seconds if you do not use a chest strap.
- + Do not pedal during the 60 seconds.

The display shows a countdown that runs from 0:60 down to 0:00 (Fig. 17).

→ When the measuring is finished, the display will show a score between F1 (very good) and F6 (very bad) (Fig. 18).

2. To end the test, press the Recovery button again.

The display returns to the main menu.

3. To reset the training data back to 0, press the Reset button.

Exercise regularly to improve your fitness.



Figure 17



Figure 18

### 3.7 Body Fat Analysis

Another way to track your fitness achievements is the body fat analysis.

1. To start the body fat analysis, from the main menu or during a paused programme, press the Body Fat button and hold onto the hand pulse sensors with both hands.

The console shows the current user (Fig. 19) and begins with the analysis (Fig. 20).

As soon as the console detects your pulse, the display shows === for eight seconds (Fig. 21), until the analysis has ended.

→ The display shows your BMI (B, Fig. 22), body fat percentage (F, Fig. 23) and the body fat symbol (BODY FAT, Fig. 24).

→ Once the analysis is done, the display automatically returns to the main menu.



Figure 19



Figure 20

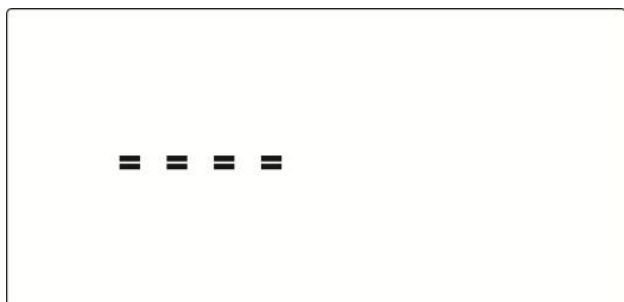

Figure 21

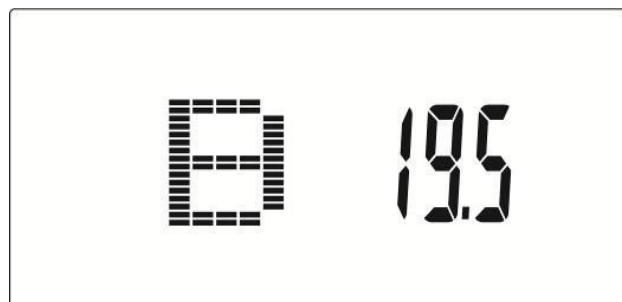

Figure 22

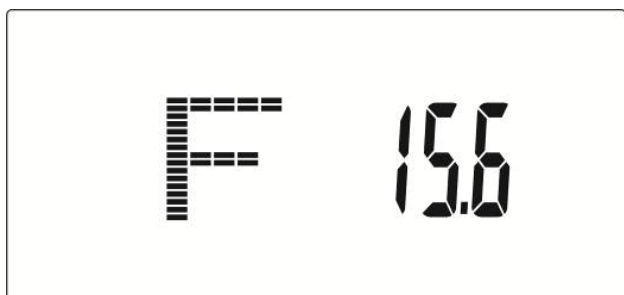

Figure 23

-	underweight
+	underweight / normal
▲	normal
◆	normal / overweight

Figure 24



## 3.8 Compatibility Training Apps

### ① NOTICE

- + Third-party apps are produced and provided by external manufacturers. Changes and availability of these apps may occur and/or differ. Sport-Tiedje holds no responsibility for the availability, functionality or content of these apps.
- + Make sure that Bluetooth is activated on your mobile device and that the console is active. To activate the console, simply tap any button except start/stop.

Your fitness equipment is compatible with several training apps. These include:

- + Kinomap
- + iConsole+
- + ZWIFT
- + MyHomeFit

### 3.8.1 Connection with Kinomap



### ① NOTICE

- + Please note that a paid subscription is required for the full functionality of Kinomap.
- + Third party apps are produced and provided by external manufacturers. Changes and availability within these apps might occur. Sport-Tiedje does not take any responsibility and can not be held liable for the availability, functionality or contents of these apps.
- + Make sure Bluetooth is enabled on your mobile device and the console is active. Otherwise, simply tap any button except Start/Stop.

1. Open Kinomap on your mobile device.
2. On the main screen, select "More" in the bar at the bottom.
3. Now select "Device management" on this page. Currently connected devices are displayed here.
4. To add a new device, tap the "+" at the top right.

### ① NOTICE

There may be slight differences in menu navigation between Android and iOS operating systems.

5. Now select the type of device. You can choose from roller trainer, exercise bike, treadmill, cross trainer and rowing machine. For the BX30 Plus, select Exercise bike/recumbent bike.
6. On the next page you will see the different brands. Select "cardiostrong" and then the BX30 Plus.
7. Now all Bluetooth sources in the surrounding area are displayed. Select a Bluetooth source that begins with i-Console .... The number that follows is also written on a small sticker on the back of the console.

*The device is now added.*

8. Return to the main menu, select a track and enjoy a great track video.

Under the QR code provided, you can watch the video of the connection with Kinomap. (<https://www.youtube.com/watch?v=KGnHAQJDIFA>)

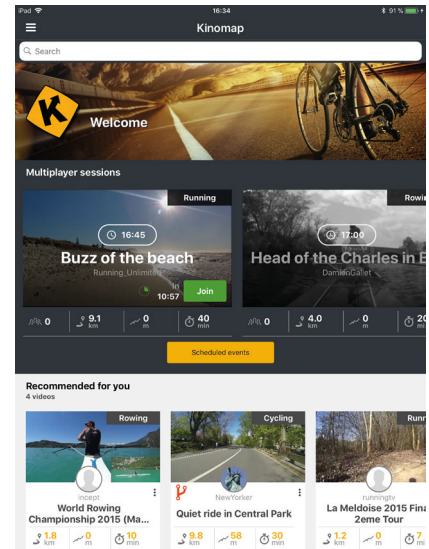
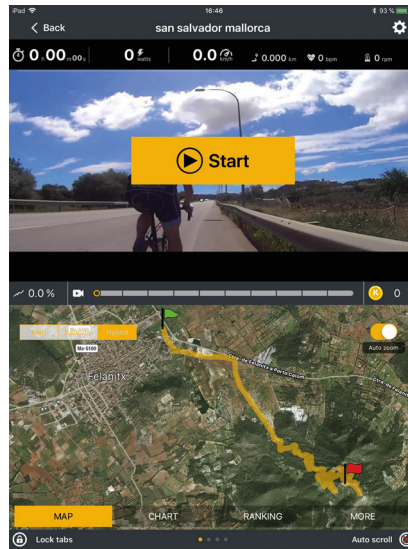
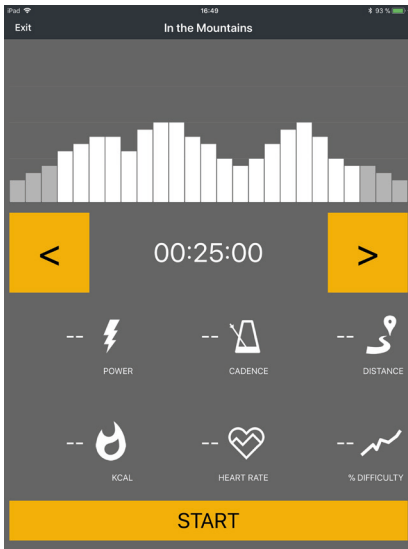

## 4.1 10 Tips for Effective Training

### 1. Set goals

What do you want to achieve with your training? Weight loss, improved endurance, prevention of disease risks, more mobility, cardiovascular training, etc. To achieve your long-term training goal, set yourself individual sub-goals, e.g. weekly or monthly goals.

### 2. Focus on the training

Try to consciously dedicate yourself only to your training session and don't get distracted.

### 3. Correct execution of movement

When performing the movement, the upper body should always be shifted slightly forward and the back kept straight. Avoid evasive movements in the hip or back area.

### 4. Correct breathing / Correct load level

Do not overexert yourself physically and mentally with too high initial exercise levels. Start slowly and increase continuously. Try to get into the habit of breathing regularly and calmly.

### 5. Sufficient hydration

Drink, drink, drink! Place a water bottle in the immediate vicinity of your workout.

### 6. Sufficient recovery phases

Give your body and muscles the necessary recovery after training. Only a rested muscle is fully operational again.

### 7. Exercise variety

Target different muscle groups with different intensities in your workout.

### 8. Correct training schedule

Every training session includes a warm-up, a cool-down and targeted stretching. This increases physical and mental performance and prevents injuries and muscle soreness.

### 9. Workout journal

Keep a record of your training sessions. List the date, resting pulse, exercise pulse, recovery pulse, resistance level, time, distance, energy consumption and fitness level.

### 10. Reward yourself

Treat yourself and your body to something good after training or after achieving a partial goal. Go to a spa or a wellness facility. Mix yourself a protein shake or enjoy a delicious salad.

## 4.2 Training Schedule

We recommend two to three training sessions per week. Each training session should be preceded by a warm-up of about 5 minutes. The training concludes with a cool-down and targeted stretching.

### Warm-up: 5 minutes

Dynamic movement of large muscle groups at low intensity. This raises the body's core temperature and gets the metabolic process going faster.

WEEK 1 + 2		Beginner		Advanced		
		Exercise bike, Crosstrainer, Indoor Bike	Treadmill		Exercise bike, Crosstrainer, Indoor Bike	Treadmill
Days	Duration	Intensity		Duration	Intensity	
Mon.	20 min.	Slow pace, without resistance	Brisk walking	30 min.	Moderate pace, Keep resistance low	Running at a slow pace
Wed.	20 min.	Slow pace, without resistance	Brisk walking	30 min.	Moderate pace, Keep resistance low	Running at a slow pace
Fri.	20 min.	Slow pace, without resistance	Brisk walking	30 min.	Moderate pace, Keep resistance low	Running at a slow pace

WEEK 3 + 4					
		Beginner		Advanced	
Days	Duration	Intensity		Duration	Intensity
Mon.	25 min.	Slow pace, without resistance/incline		35 min.	Vary the tempo, Keep resistance low
Wed.	25 min.	Slow pace, without resistance/incline		35 min.	Vary the tempo, Keep resistance low
Fri.	25 min.	Slow pace, without resistance/incline		35 min.	Vary the tempo, Keep resistance low

WEEK 5 + 6				
	Beginner		Advanced	
Days	Duration	Intensity	Duration	Intensity
Mon.	30 min.	Moderate pace, Keep resistance low	40 min.	Vary the tempo, Keep resistance low
Wed.	30 min.	Moderate pace, Keep resistance low	40 min.	Vary the tempo, Keep resistance low
Fri.	30 min.	Moderate pace, Keep resistance low	40 min.	Vary the tempo, Keep resistance low

WEEK 7 + 8				
	Beginner		Advanced	
Days	Duration	Intensity	Duration	Intensity
Mon.	35 min.	Vary the tempo, Keep resistance low	45 min.	Vary the tempo, Increase resistance
Wed.	35 min.	Vary the tempo, Keep resistance low	45 min.	Vary the tempo, Increase resistance
Fri.	35 min.	Vary the tempo, Keep resistance low	45 min.	Vary the tempo, Increase resistance

WEEK 9 + 10				
	Beginner		Advanced	
Days	Duration	Intensity	Duration	Intensity
Mon.	40 min.	Vary the tempo, Keep resistance low	50 min.	Vary the tempo, Increase resistance
Wed.	40 min.	Vary the tempo, Keep resistance low	50 min.	Vary the tempo, Increase resistance
Fri.	40 min.	Vary the tempo, Keep resistance low	50 min.	Vary the tempo, Increase resistance

### Cool-Down: 5 minutes

Finish the workout at low resistance and a steady pace. Gently let the body cool down.

## 4.3 Stretching Exercises for Leg and Chest Muscles

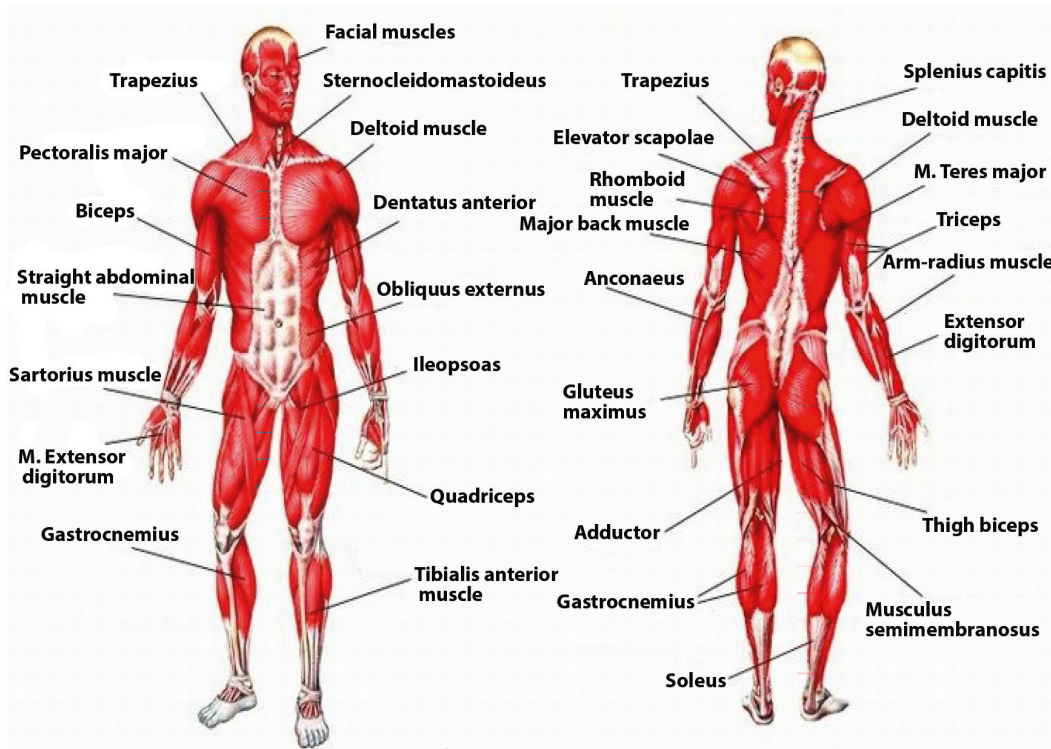

### 1. Exercise: Stretching of front thigh / leg extension (quadriceps)

- + Stable position, grab arches of feet
- + Pull heel towards buttocks, knee points downwards (no abduction)
- + Straight upper body, avoid tilting the pelvic forward (hollow back) by tensing the abdominal muscles
- + Switch legs

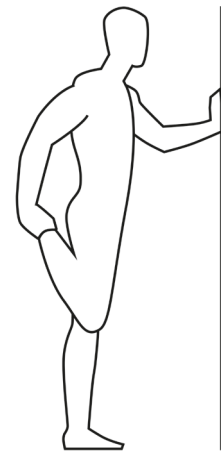

### 2. Exercise: Stretching the back thigh / leg curl (hamstring)

- + Pull thigh towards upper body with both hands
- + Stretch through increased stretching in the knee joint
- + The lower leg maintains contact with the floor, keep hips bent
- + Switch legs

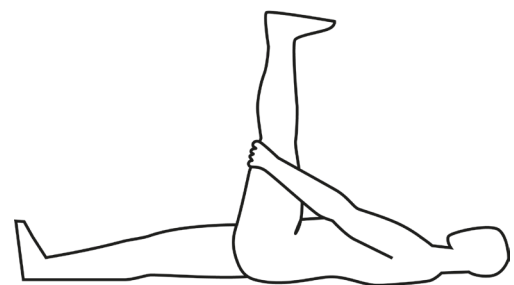

### 3. Exercise: Stretching the calf muscles (gastrocnemius)

- + Place feet parallel to each other pointing forward, the heels touch the floor
- + Support yourself on a chair coming from a lunge
- + Move your body weight to the front leg, press your heel from the rear leg towards the floor and hold the contact
- + Slowly stretch your knee of the rear leg until you feel the stretch in your calves
- + Switch legs

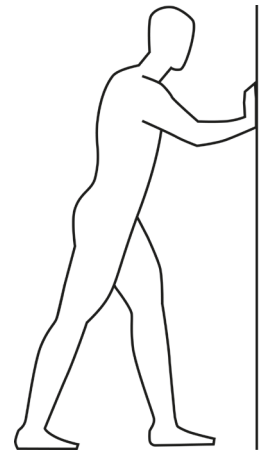

### 4. Exercise: Stretching the chest muscles (pectoralis major)

- + Stand parallel to a wall
- + Place your forearm at 90° to the wall with the elbow just above shoulder height
- + Turn your head and upper body gradually to the opposite sides until you feel a stretch in the front chest, of the shoulder being leaned on
- + Pay attention to tension in your abdominal and gluteal muscles
- + Your weight is on your front leg
- + Switch side

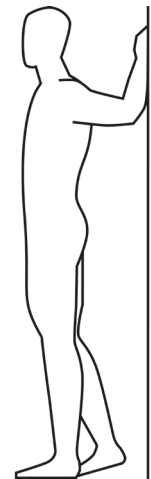









#### ⓘ NOTICE

All recommendations of these instructions apply solely to healthy people and are not suitable for those with heart or cardiovascular problems. All of the tips are intended only as a guide to help you create a workout. Your physician can offer appropriate advice for specific, personal requirements.

**We hope you enjoy your workout and have a lot of success!**

## 4.4 Workout Journal



Date



Distance



Time (min.)



Resistance level



Training weight



Ø Pulse



Calories burnt



I feel ...



Body weight



## 4.5 Fitness Guide

If you would like to take a closer look at the general topic of fitness and everything that goes with it, we have prepared a fitness guide for you that is available as a PDF file. It contains helpful information on nutrition, training zones and many other tips to help you increase your training success.

Simply scan the QR code provided with the camera function or QR code scanner app of your smartphone or tablet.

\*The fitness guide is currently available in German language.



### 5.1 General Instructions

► **ATTENTION**

- + Make sure that the equipment is protected from moisture, dust and dirt in the selected storage location. The storage location should be dry and well ventilated and have a constant ambient temperature between 5°C and 45°C.

⚠ **WARNING**

- + The storage location should be chosen so that improper use by third parties or children can be prevented.
- + If your equipment does not have transportation wheels, the equipment must be disassembled before transportation.

### 5.2 Transportation Wheels

► **ATTENTION**

If you want to transport your equipment over particularly sensitive and soft floor coverings, such as parquet, planks or laminate, lay out the transport route with cardboard or similar to avoid possible floor damage.

1. Pull the handle and lift the equipment until the weight is transferred to the transportation wheels. After that, you easily can move the equipment to a new position. For long transport distances the equipment should be disassembled and safely packed.
2. Select the new location by following the instructions in the section 1.4 of this manual.

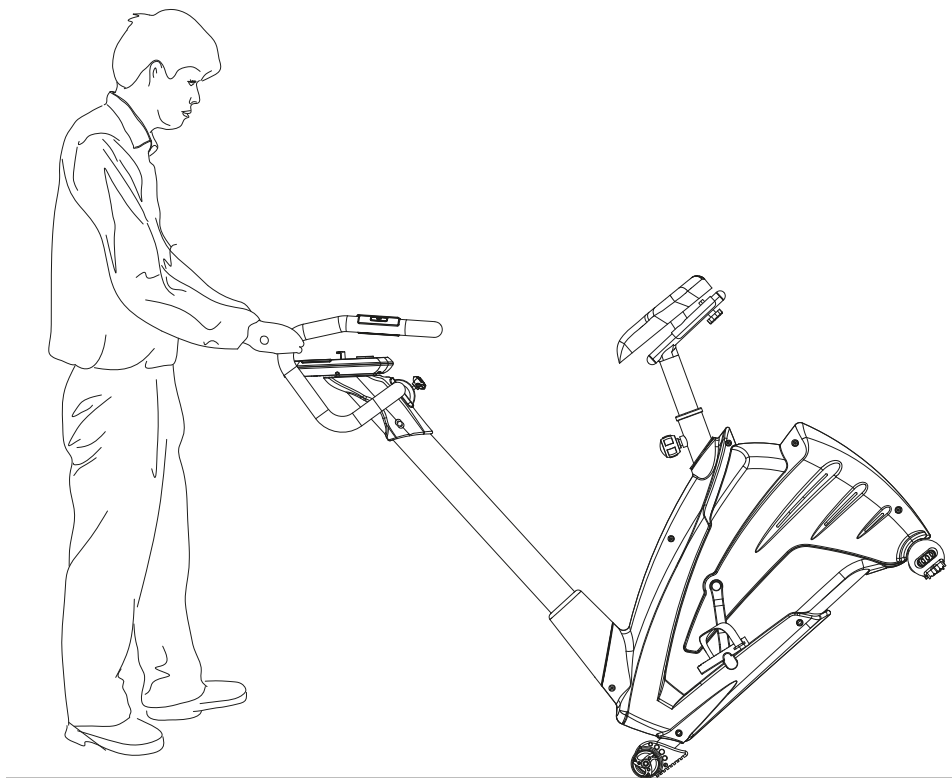

## 6.1 General Instructions



### WARNING

- + Do not make any improper changes to the equipment.



### CAUTION

- + Damaged or worn components may affect your safety and the life of the equipment. Safety can only be guaranteed if you check the equipment regularly for wear and damage. Replace damaged or worn components immediately. In such a case, contact the contract partner. The equipment must not be used until it has been repaired. If necessary, use only original spare parts.

### ATTENTION

- + Parts subjects to wear: Due to frequent adjustment, the pedal straps can be particularly susceptible to wear.
- + In addition to the instructions and recommendations for maintenance and care given here, additional service and/or repair work may be necessary; this must only be carried out by authorised service technicians.

## 6.2 Faults and Fault Diagnosis

The equipment undergoes regular quality controls during production. Nevertheless, faults or malfunctions may occur. Frequently, individual parts are responsible for these disturbances, an exchange is usually sufficient. Please refer to the following overview for the most common errors and how to correct them. If the equipment still does not function properly, contact your contract partner.

Fault	Cause	Solution
Crackling noise in pedal area	Loose pedals	Tighten the pedals
Equipment wobbles	Equipment is not level	Adjust the supporting feet
Handlebar/saddle wobbles	Screws are loose	Tighten screws
Display does not turn on	Power is disconnected	Check all screw connections and see if the plug is plugged in
No pulse reading	<ul style="list-style-type: none"> <li>+ Interference in the room</li> <li>+ unsuitable chest strap</li> <li>+ chest strap is incorrectly positioned</li> <li>+ batteries are empty</li> </ul>	<ul style="list-style-type: none"> <li>+ Eliminate sources of interference (e. g. mobile phone, loudspeaker, etc.)</li> <li>+ Use a suitable chest strap (see recommended accessories)</li> <li>+ Reposition the chest strap and/or moisten the electrodes</li> <li>+ Change the batteries</li> </ul>

## 6.3 Error Codes and Troubleshooting

The electronics of the equipment continuously carries out tests. In case of deviations, an error code appears on the display and normal operation is stopped for your safety.

- + The display shows ===> The hand pulse sensors aren't being held properly with both hands.
- + E1 → A heart rate has not been detected.
- + E4 → This error is shown when the results of FAT % and BMI is lower than 5 or over 50.

**Please contact Sport-Tiedje for technical support.**

## 6.4 Maintenance and Inspection Calendar

To avoid damage from body sweat, the equipment must be cleaned with a damp towel (no solvents!) after each training session.

The following routine tasks must be performed at the specified intervals:

Part	Weekly	Monthly	Quarterly	Half-yearly	Yearly
Display console	C	I			
Tighten pedals				I	
Plastic covers	C	I			
Screws and cable connections		I			
Seat rail		I			
Check pedals for tightness		I			
Legend: C = clean; I = inspect					

By scanning the QR code with the camera function or QR code scanner app of your smartphone/tablet, a video on general maintenance of an exercise bike opens on YouTube. The video serves to illustrate the maintenance points described in this manual.

Please note that the video may not be available in your language or with appropriate subtitles.

If you cannot scan QR codes, you can access all Sport-Tiedje videos on YouTube by first opening YouTube and entering "Sport-Tiedje" in the search field.



## 7 DISPOSAL

---

At the end of its operational life, this equipment cannot be disposed of in normal household waste. Instead, it must be disposed of via an electricals recycling centre. Further information can be obtained from your local authority's recycling service.

The materials can be recycled as per their symbols. Through the reuse, recycling of materials or other forms of recovery of old equipment, you make an important contribution to the protection of the environment.



## 8 RECOMMENDED ACCESSORIES

To make your training experience even more efficient and pleasant, we recommend that you add suiting accessories to your fitness equipment. For exercise bikes this could for example be a **floor mat**, which makes your fitness equipment stand more securely and also protects the floor from sweat or **silicone spray** to keep moving parts in good shape. For many exercise bikes it is possible to replace the **saddle** or **pedals**, as these are usually the same mounts used on bicycles.

If you have purchased a fitness machine with pulse training and want to train your heart rate, we strongly recommend that you use a compatible **chest strap**, as this ensures optimum transmission of the heart rate.



Our range of accessories offers the highest quality and makes training even better. If you would like to find out more about compatible accessories, please go to the detail page of the product in our webshop (the easiest way is to enter the article number in the search field above) and go to the recommended accessories on this page. Alternatively, you can use the QR code provided. Of course, you can also contact our customer service: by telephone, e-mail, in one of our branches or via our social media channels. We will be happy to advise you!



floor mat



chest strap



chest strap contact gel



towels



silicone spray

## 9.1 Serial Number and Model Name

In order to provide you with the best possible service, please have the model name, article number, serial number, exploded drawing and parts list ready. The corresponding contact options can be found in chapter 11 of this operating manual.

**NOTICE**

The serial number of your equipment is unique. The serial number and other information can be found on the typeplate on the equipment. For the exact position and explanation of the type plate, please refer to the illustrations A and B.

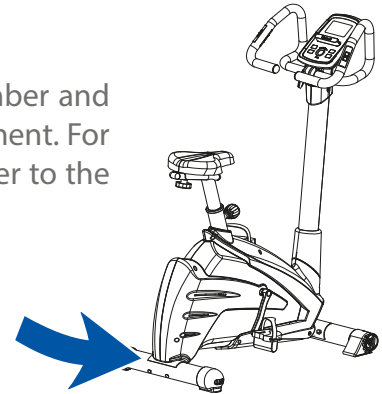

Illustration A

Enter the serial number in the appropriate field.

**Serial number:**

**Brand / Category:**

**Model Name:**

**Article Number:**

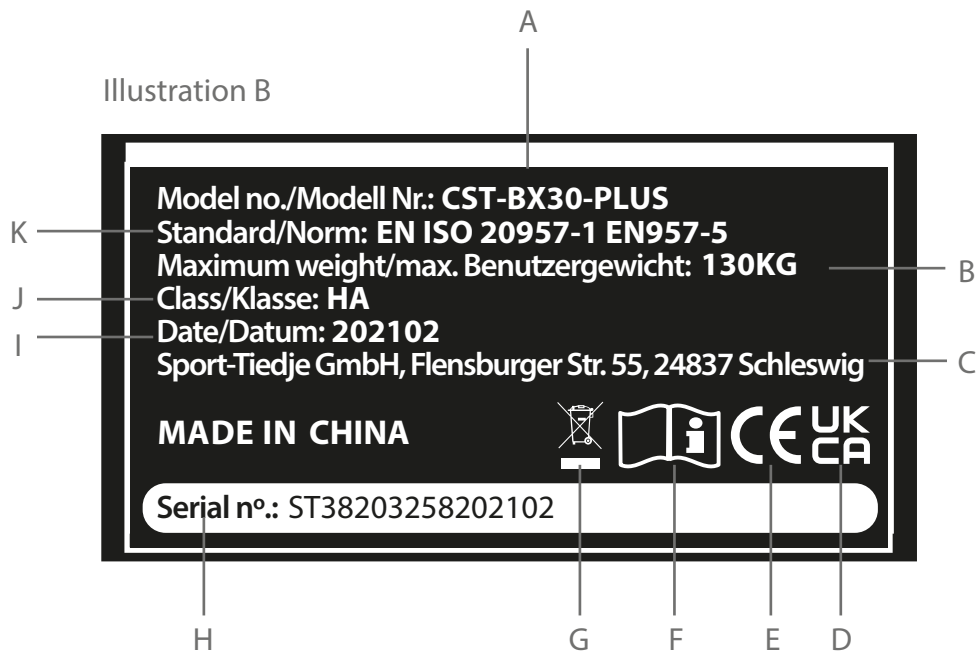

- A Model number of the equipment
- B Maximum user weight
- C Name and full address of the importer
- D UKCA marking
- E CE marking
- F Refer to the manual
- G Disposal symbol: this equipment cannot be disposed of in normal household waste
- H Individual serial number
- I Production date (YY/DD/MM)
- J Classification: H (Home use), A (high accuracy)
- K The equipment has been tested according to the specified standards



## 9.2 Parts List

No.	Name	Supplier Parts No.	Specification	Qty.
1	Main frame	805E2-3-1000-J5		1
2	Rear stabilizer	70501-6-2107-J1	D76x1.5Tx480L	1
3	Front stabilizer	70501-6-2101-J0	D76x1.5Tx480L	1
4	Adjustable foot cap	55486-L-0076-31	D76*86	2
5L	Left foot cap	554C0-H-0076-31	D76*120L	1
5R	Right foot cap	554C0-R-0076-31	D76*120L	1
6	Domed nut M8*1.25*15L	55208-6-2015-FA	M8x1.25x15L	4
7	Square neck bolt M8*1.25*90L	50508-5-0090-F3	M8x1.25x90L	4
8	Oval cap 25*50*28L	55328-3-2550-B1	25*50*28L	2
9	Seat post	71402-3-2200-J3		1
10	Seat	58001-6-1351-B0	LS-A28	1
11	Adjustable seat tube	18300-3-4000-J1		1
14	Screw ST4*1.41*15L	52804-2-0015-D0	ST4*1.41*15L	2
15	Adapter	737L5-6-2584-00	output:9V,2A	1
17	Screw knob D60*32L (M8*1.25)	52008-2-0022-B0	D60x32L(M8x1.25)	1
18	Flat washer D25*D8.5*2T	55108-1-2520-CA	D25xD8.5x2T	1
19	Tension control cable D1.5*230L	706E2-6-2601-00	D1.5*230 L	1
20	Allen bolt M8*1.25*20L	50308-5-0020-F0	M8*1.25*20L	4
21	Multi-groove belt	58004-6-1030-01	440 J5 (1118 J5)	1
22	Waved washer D22*D17*0.3T	55117-5-2203-DA	D22xD17x0.3T	2
23	Flat washer D23*D17.2*1.5T	55117-1-2315-NA	D23*D17.2*1.5T	1
24	Round magnet	174R4-6-2574-00	M02	1
25	Left chain cover	80500-6-4501-BZ0	865*80*500	1
26	Right chain cover	80500-6-4502-BZ0	895*80*500	1
27	Pulley Wheel	58008-6-1039-D1	D250*17*3T	1
28	Upper protective cover	80500-6-4580-BZ0	D100*210	1
29	Handlebar post	805S0-3-2000-J4		1
30	Handle pulse	737L6-6-2478-00	100.3*29.5*0.4T	4
31	Ball knob D50*M16*22*D8	52916-2-0022-G1	D50xM16x22xD8	1
32	Nylon nut M10*1.5*10T	55210-1-2010-NA	M10x1.5x10T	1
33	Bolt cap D23*6.5	170LR-6-2779-C0	D23x6.5	2
34	Bolt M8*1.25*25	50108-2-0025-U0	M8x1.25x25	2

35L	Left crank	58007-6-1056-03	6 1/2"x9/16"-20UNF	1
35R	Right crank	58007-6-1057-03	6 1/2"x9/16"-20UNF	1
36	Handlebar	805K2-3-2400-BB0		1
37	T-shaped knob M8*1.25*65	51908-2-0065-B1	M8x1.25x65	1
38	Computer SM2560-31	805K2-6-2501-B0	SM2560-31	1
39	Upper computer cable 1000L	73002-6-2572-00	1000L	1
40	Lower computer cable 300L	805E2-6-2573-00	300L	1
41L	Left computer bracket	80500-6-2592-B0		1
41R	Right computer bracket	80500-6-2593-B0		1
42	Cover 80.6*56*52.5	80502-6-2481-B0	80.6*56*52.5	1
43	Flat washer D16*D8.5*1.2T	55108-1-1612-FA	D16xD8.5x1.2T	1
44	Spring washer D15.4*D8.2*2T	55108-2-1520-FA	D15.4xD8.2x2T	1
45	Bushing D8.2*D12.7*33	58002-6-1026-D0	D8.2xD12.7x33	1
46-1L	Pedal Strap left	58029-6-1032-B1		1
46-1R	Pedal Strap right	58029-6-1032-B2		1
46L/R	Pedal	58029-6-1032-B0	JD-22A	1
47	C-ring S-17 (1T)	55517-1-0010-00	S-17(1T)	1
48	Protective ring for chain cover	80500-6-4503-B0	60.5*72*7T	1
49	Bolt M6*1.0*15L	50106-5-0015-C0	M6x1.0x15L	4
50	Flat washer D50*D10*2.0T	55110-1-5020-NA	D50xD10x2.0T	1
51	Curved washer D22*D8.5*1.5T	55108-3-2215-FA	D22*D8.5*1.5T	8
52	Crank axle	803MC-3-2903-00		1
53	Spring washer D15.4*D8.2*2T	55108-2-1520-FA	D15.4 XD8.2x2T	8
54	Sensor cable 150L	80202-6-2576-00	150L	1
55	Bearing #6003ZZ	58006-6-1018-00	#6003ZZ	2
56	Nylon nut 3/8"-26UNF*6.5T	18600-6-3175-N1	3/8"-26UNF*6.5T	2
57	Flat washer D30*D10*3.2T	55110-1-3032-01	D30xD10x3.2T	1
58	Fixing plate for idle wheel	17402-3-1600-N4		1
59	Bolt M5*0.8*10L	52605-2-0010-D0	M5x0.8x10L	5
60	Plastic flat washer D50*D10*1.0T	55110-1-5010-BF	D50*D10*1.0T	2
61	Idle wheel D23.8*D38*24	16100-6-1671-04	D23.8xD38x24	1
62	Screw ST4.2*1.41*15L	53342-2-0015-N0	ST4.2x1.4x15L	8
63	Spacer D22.5*D17.2*6.4T	80700-6-2781-00	D22.5*D17.2*6.4T	1
64	Magnetic system	805E2-2-3100-00		1

65	Motor	73002-6-2571-00		1
66	Electric cable 350L	180E1-6-2596-00	350L	1
67	Anti-loose nut M6*1.0*6T	55206-1-2006-CA	M6x1.0x6T	4
68	Spring D2.2*D14*55L	58003-6-1013-N1	D2.2*D14*55L	1
69	Screw ST4*1.41*15L	50904-2-0015-D0	ST4*1.41*15L	7
70	Inner tube D66*D50.3*170L	67500-6-1071-B1	D66xD52x170L	1
71	Buffer D9*D5.8*13	55306-4-0013-B9	D9*D5.8*13	1
72	Inner tube D71.5*108L	70802-6-1071-B0	D71.5*108L	1
74	Bolt M8*52L	50108-5-0052-N3	M8*52L	1
75	Anti-loose nut M8*1.25*8T	55208-1-2008-NA	M8*1.25*8T	1
76	Magnetic fixed plate	84002-3-3200-N1		1
77	Bolt M6*65L	50106-5-0065-N0	M6*1*65L	1
78	Spring D1.2*55L	58003-6-1035-01	D1.2*55L	1
79	Nut M6*1*6T	55206-2-2006-NA	M6*1*6T	1
80	Flat washer D13*D6.5*1.0T	55106-1-1310-NA	D13*D6.5*1.0T	1
81	Nylon washer D6*D19*1.5T	55106-1-1915-B1	D6*D19*1.5T	1
82	Anti-loose nut M6*1*6T	55206-1-2006-NA	M6*1*6T	1
83	upper fixed plate for Handle pulse	737L6-6-2491-B0	40*15.2	2
84	under fixed plate for Handle pulse	737L6-6-2492-B0	40*15.2	2
85	Screw ST4*1.41*15L	50904-2-0015-F0	ST4x1.41x15L	2
86	Handle pulse cable 900L	74551-6-2479-00	900L	2

### 9.3 Exploded Drawing

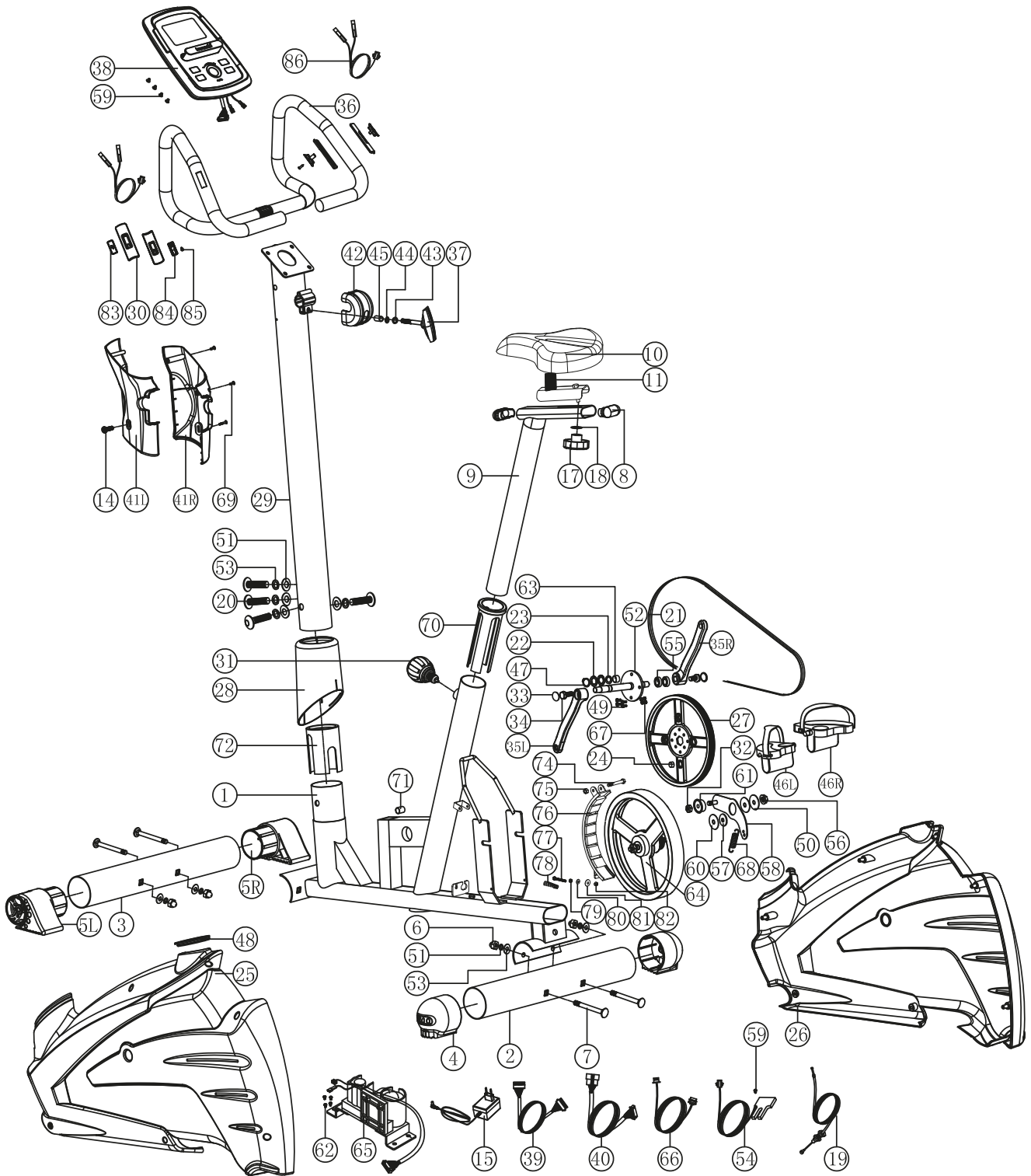

Training equipment from cardiostrong® is subject to strict quality control. However, if a fitness equipment purchased from us does not work perfectly, we take it very seriously and ask you to contact our customer service as indicated. We are happy to help you by phone via our service hotline.

**Error Descriptions**

Your fitness equipment is developed for long-term, high-quality training. However, should a problem arise, please first read the operating instructions. For further assistance, please contact your contract partner or call our service hotline. To ensure your problem is solved as quickly as possible, please describe the defect as exactly as possible.

In addition to the statutory warranty, we provide a warranty for every fitness equipment purchased from us according to the following provisions.

**Your statutory rights are not affected.****Warranty**

The warranty is the first/original buyer and/or any person who received a newly purchased product as a gift from the original buyer.

**Warranty period**

The warranty periods, shown on our web shop, begin on delivery of the fitness equipment. The respective warranty periods for your equipment can be found on its product website.

**Repair Costs**

According to our choice, there will either be a repair, a replacement of individual damaged parts or a complete replacement. Spare parts, that have to be mounted while assembling the equipment, have to be replaced by the warranty holder personally and are not a part of repair. After the expiration of the warranty period, the responsibility for parts costs, repair costs, installation costs and delivery costs lies with the warranty holder.

**The terms of use are defined as follows:**

- + Home use: solely for private use in private households up to 3 hours per day
- + Semi-professional use: up to 6 hours per day (e. g. rehabilitation centres, hotels, clubs, company gyms)
- + Professional use: more than 6 hours per day (e. g. commercial gyms)

**Warranty Service**

Within the warranty period, equipment which develops faults as a result of material or manufacturing defects, will be repaired or replaced at our discretion. Ownership of equipment or parts of equipment which have been replaced is transferred to us. The warranty period is not extended nor does a new warranty period begin following repair or replacement under the warranty.

## Warranty Conditions

For the warranty to be valid, the following steps must be taken:

Please contact our customer service by email or phone. If the product under warranty has to be sent in for repair, the seller bears costs. After expiry of the warranty, the buyer bears the costs of transport and insurance. If the fault is covered by our warranty, you will receive a new or repaired equipment in return.

### Warranty claims are invalid in case of damage resulting from:

- + misuse or improper handling
- + environmental influences (moisture, heat, electrical surge, dust, etc.)
- + failure to follow the current safety measures for the equipment
- + failure to follow the operating instructions
- + use of force (e. g. hitting, kicking, falling)
- + interventions which were not carried out by one of our authorized service centres
- + unauthorised repair attempts

### Proof of Purchase and Serial Number

Please make sure that you are able to provide the appropriate receipt when claiming on your warranty. So that we can clearly identify the model of your equipment, and for the purposes of our quality control, you will need to give the serial number of your equipment, when contacting the service team. Where possible please have your serial number and your customer number ready when you call our service hotline. It will help us to deal with your request swiftly.







































If you cannot find the serial number on your fitness equipment, our service team is at your disposal to offer further information.

### Service outside of the Warranty Period

We are also happy to issue an individual cost estimate if there is a problem with your fitness equipment after the warranty has expired, or in cases which do not fall under the terms of the warranty, e. g. normal wear and tear. Please contact our customer service team to find a quick and cost-effective solution to your problem. In such a case you will be responsible for the delivery costs.

### Communication

Many problems can be solved just by speaking to us as your specialist supplier. We know how important it is to you as a user of the fitness equipment to have problems solved quickly and simply, so you can enjoy working out with minimal interruption. For that reason, we also want to resolve your queries quickly and in a straightforward manner. Thus, please always keep your customer number and the serial number of the faulty equipment handy.

DE	DK	FR
<p><b>TECHNIK</b></p> <p> +49 4621 4210-900   +49 4621 4210-698   technik@sport-tiedje.de   Öffnungszeiten entnehmen Sie unserer Homepage.</p> <p><b>SERVICE</b></p> <p> 0800 20 20277 (kostenlos)   04621 4210 - 0   info@sport-tiedje.de   Öffnungszeiten entnehmen Sie unserer Homepage.</p>	<p><b>TEKNIK OG SERVICE</b></p> <p> 80 90 16 50  +49 4621 4210-945   info@fitshop.dk   Åbningstider kan findes på hjemmesiden.</p>	<p><b>TECHNIQUE &amp; SERVICE</b></p> <p> +33 (0) 189 530984  +49 4621 42 10 933   info@fitshop.fr   Vous trouverez les heures d'ouverture sur notre site Internet.</p>
	PL	BE
	<p><b>DZIAŁ TECHNICZNY I SERWIS</b></p> <p> 22 307 43 21  +49 4621 42 10-948   info@fitshop.pl   Godziny otwarcia można znaleźć na stronie głównej.</p>	<p><b>TECHNIQUE &amp; SERVICE</b></p> <p> 02 732 46 77  +49 4621 4210 933   info@fitshop.be   Vous trouverez les heures d'ouverture sur notre site Internet.</p>
UK	NL	INT
<p><b>CUSTOMER CARE POWERHOUSE</b></p> <p> +44 141 737 2249 or  +44 141 876 3972   customercare@powerhouse-fitness.co.uk   You can find the opening hours on our homepage.</p>	<p><b>TECHNISCHE DIENST &amp; SERVICE</b></p> <p> +31 172 619961   service@fitshop.nl   De openingstijden vindt u op onze homepage.</p>	<p><b>TECHNICAL SUPPORT &amp; SERVICE</b></p> <p> +49 4621 4210-944   service-int@sport-tiedje.de   You can find the opening hours on our homepage.</p>
ES	AT	CH
<p><b>TECNOLOGÍA Y SERVICIOS</b></p> <p> 911 238 029   info@fitshop.es   Consulta nuestro horario de apertura en la página web.</p>	<p><b>TECHNIK &amp; SERVICE</b></p> <p> 0800 20 20277 (Freecall)  +49 4621 42 10-0   info@sport-tiedje.at   Öffnungszeiten entnehmen Sie unserer Homepage.</p>	<p><b>TECHNIK &amp; SERVICE</b></p> <p> 0800 202 027  +49 4621 42 10-0   info@sport-tiedje.ch   Öffnungszeiten entnehmen Sie unserer Homepage.</p>

Please find a detailed overview including address and opening hours for all stores of the Sport-Tiedje Group in Germany and abroad on the following website:

[www.sport-tiedje.com/en/stores](http://www.sport-tiedje.com/en/stores)

# WE LIVE FITNESS

## WEBSHOP AND SOCIAL MEDIA

Sport-Tiedje is Europe's largest specialist store for home fitness equipment with currently over 70 stores and one of the world's most renowned online mail order companies for fitness equipment. Private customers order via the 25 web shops in the respective national language or have their desired equipment assembled on site. In addition, the company supplies fitness studios, hotels, sports clubs, companies and physio practices with professional equipment for endurance and strength training.

Sport-Tiedje offers a wide range of fitness equipment from renowned manufacturers, high-quality in-house developments and comprehensive services, such as a build-up service and sports scientific advice before and after the purchase. The company employs numerous sports scientists, fitness trainers and competitive athletes.

Visit us also on our social media platforms or our blog!



[www.sport-tiedje.co.uk](http://www.sport-tiedje.co.uk)  
[www.sport-tiedje.de/blog](http://www.sport-tiedje.de/blog)



[www.facebook.com/SportTiedje](http://www.facebook.com/SportTiedje)



[www.instagram.com/sporttiedje](http://www.instagram.com/sporttiedje)



[www.youtube.com/user/sporttiedje](http://www.youtube.com/user/sporttiedje)

**TAURUS**

**cardiostrong**

**BODYCRAFT**

**cardiojump**

**DUKEFITNESS**

**DARWIN**



Notes

Notes

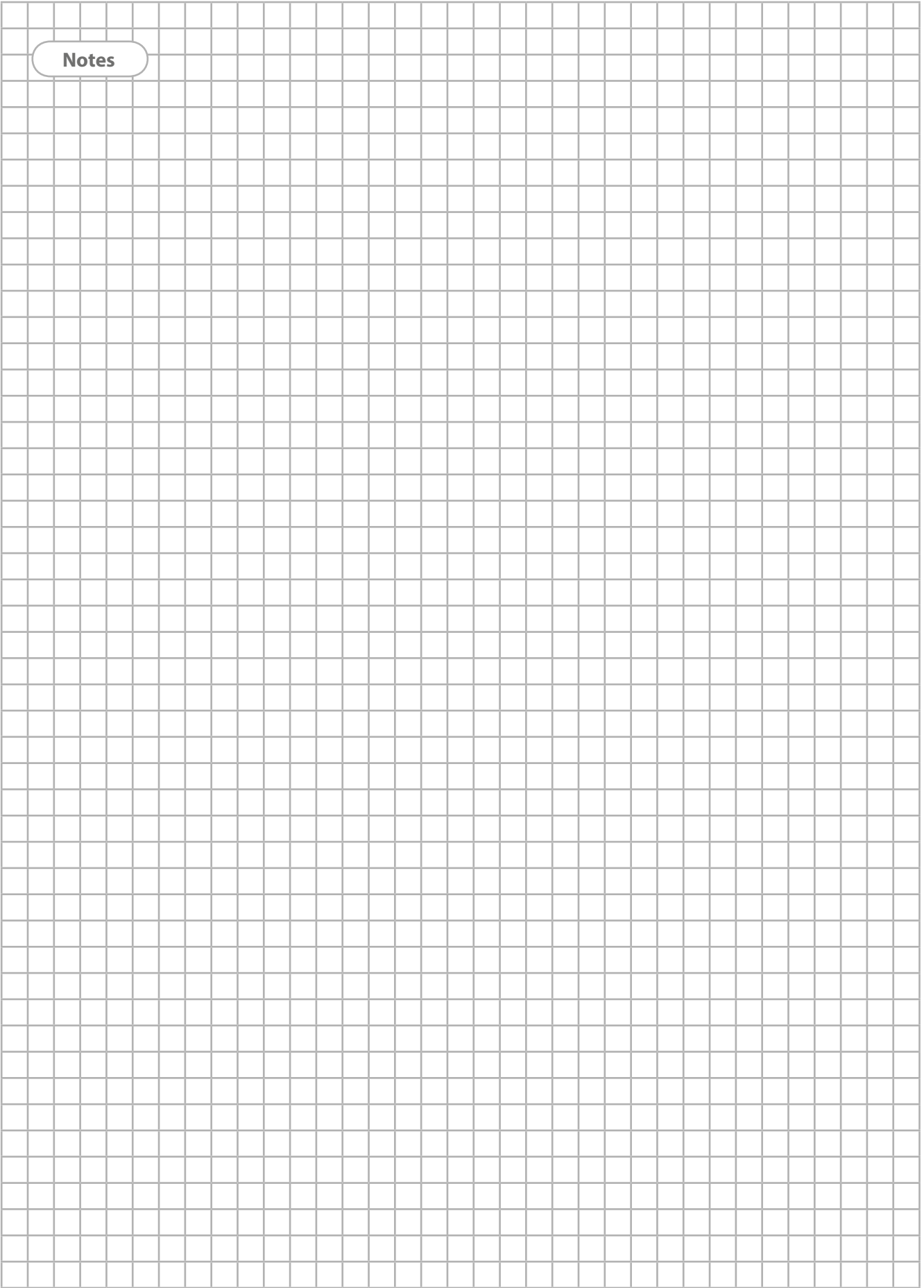





Upright Bike **BX30** Plus