

BODYCRAFT

Assembly and Operating Instructions

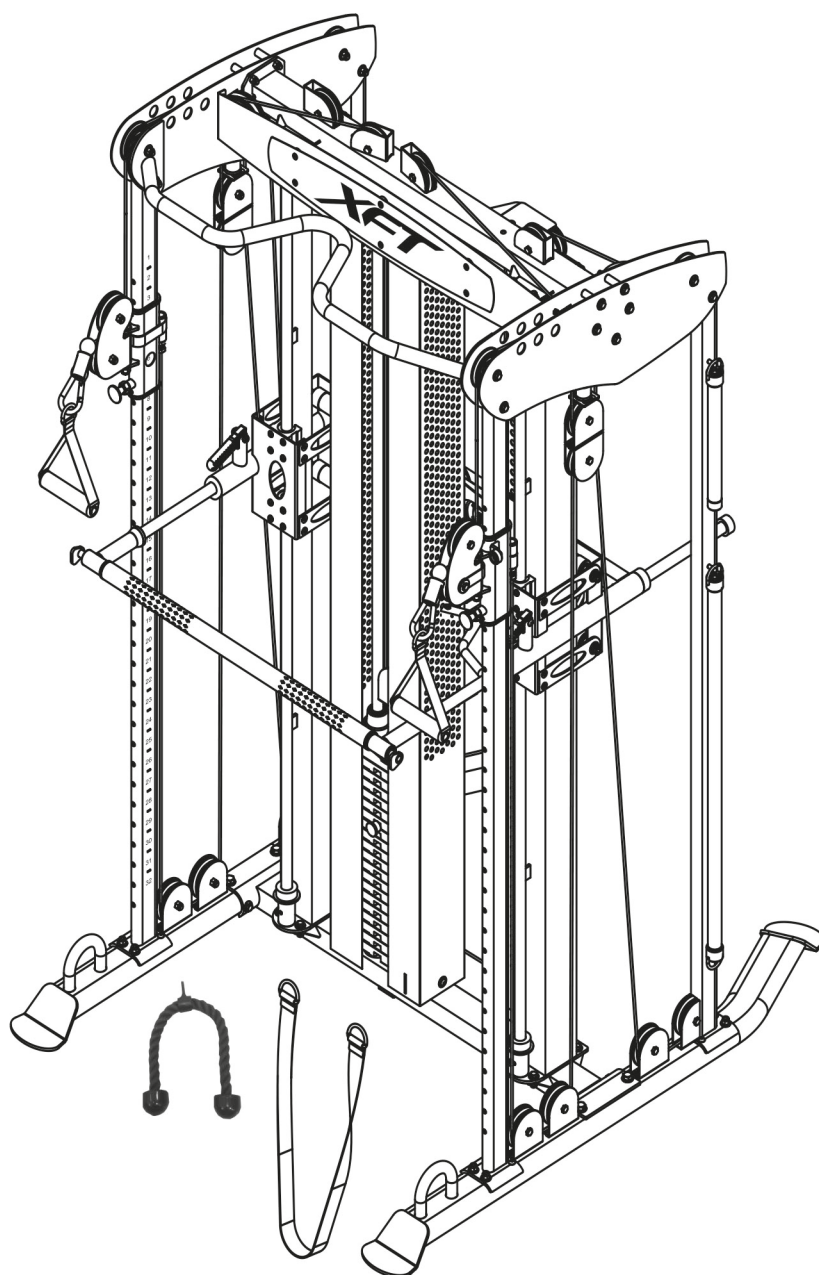

max. 150 kg



~ 180 Min.



305 / 328 kg

L 155 | W 127 | H 211

BCXFT.01.01

Art. No. BC-XFT

BodyCraft XFT Functional Trainer

Content

1	GENERAL INFORMATION	7
1.1	Technical Data	7
1.2	Personal Safety	8
1.3	Set-Up Place	9
2	ASSEMBLY	10
2.1	General Instructions	10
2.2	Scope of Delivery	11
2.3	Assembly	14
3	STORAGE AND TRANSPORT	46
3.1	General Instructions	46
4	TROUBLESHOOTING, CARE AND MAINTENANCE	47
4.1	General Instructions	47
4.2	Faults and Fault Diagnosis	47
4.3	Maintenance and Inspection Calendar	48
5	DISPOSAL	48
6	RECOMMENDED ACCESSORIES	49
7	ORDERING SPARE PARTS	50
7.1	Serial Number and Model Name	50
7.2	Parts List	51
7.3	Exploded Drawing	54
8	WARRANTY	55
9	CONTACT	57

Dear customer,

thank you for choosing training equipment of the brand Bodycraft. Bodycraft equipment inspires with its multifunctionality and excellent quality. In terms of innovation and technology, it is one of the highest quality fitness equipment for home use. Bodycraft multi gyms, for example, offer a very wide range of exercise possibilities. This ranges from traditional strength training such as bench presses and rehabilitation exercises to workout for complex sports like golf, tennis or badminton.

Intended Use

The equipment may only be used for its intended purpose.

The equipment is only suitable for home use. The equipment is not suitable for semi-professional (e.g. hospitals, associations, hotels, schools, etc.) and commercial or professional use (e.g. fitness studios).

Legal Notice

Sport-Tiedje GmbH
Europe's No. 1 for home fitness

International Headquarters
Flensburger Straße 55
24837 Schleswig
Germany

Management:
Christian Grau
Sebastian Campmann
Dr. Bernhard Schenkel
No. HRB 1000 SL
Local Court Flensburg
European VAT Number: DE813211547

Disclaimer

BODYCRAFT

BodyCraft® is a registered brand of the company Fitness Authority Industrial Co., LTD. All rights reserved. Any use of this trademark without the explicit written permission of Fitness Authority Industrial Co., LTD is prohibited.

Product and manual are subject to change. Technical data can be changed without advance notice.

ABOUT THIS MANUAL

Please carefully read the entire manual before installation and first use. The manual will help you to quickly set up the system and explains how to safely use it. Make sure that all persons exercising with the equipment (especially children and persons with physical, sensory, mental or motor disabilities) are informed about this manual and its contents in advance. In case of doubt, responsible persons must supervise the use of the equipment.

Due to ongoing changes and software optimisations, the manual may have to be updated. If you notice any discrepancies during assembly or use, please refer to the manual uploaded to the webshop. The latest manual is always available there.

This equipment has been manufactured according to the latest safety knowledge. As far as possible, potential safety hazards which could cause injury have been eliminated. Make sure to carefully follow the instructions and that all parts are securely in place. If required, read through the instructions again to correct any mistakes.



Please pay close attention to the safety and maintenance instructions given here. The contract partner cannot be held liable for damage to health, accidents or damage to the equipment when it is not used in accordance with these instructions.

The following safety instructions may appear in this manual:

► **ATTENTION**

This notice indicates potentially hazardous situations which, if not avoided, may result in property damage.

⚠ **CAUTION**

This notice indicates potentially hazardous situations which, if not avoided, may result in slight or minor injuries!

⚠ **WARNING**

This notice indicates potentially hazardous situations which, if not avoided, may result in death or serious injuries!

⚠ **DANGER**

This notice indicates potentially hazardous situations which, if not avoided, will result in death or serious injuries!

ⓘ **NOTICE**

This notice indicates further useful information.

Retain these instructions in a safe place for future reference, maintenance or when ordering replacement parts.

1.1 Technical Data

Weight and Dimensions

XFT

Packaging dimensions (L x W x H) and article weight (gross, incl. packaging) approx.:

Box 1:	199.6 cm x 40 cm x 11.7 cm	65.8 kg
Box 2:	159 cm x 59.6 cm x 25.4 cm	69.2 kg
Box 3:	112.3 cm x 49.1 cm x 31.1 cm	58.1 kg
Box 4:	212.7 cm x 28.5 cm x 15.5 cm	60 kg
Box 5:	196.8 cm x 18.4 cm x 11.7 cm	11.8 kg

Weight Plates

67.5 kg/150 lbs:	28 cm x 19 cm x 15 cm	31.27 kg (2x)
90 kg/200 lbs:	28 cm x 19 cm x 15 cm	31.27 kg (2x)
	27 cm x 14 cm x 13 cm	22.42 kg (1x)

Set-up dimensions (L x W x H):	155 cm x 127 cm x 211 cm
Article weight (net, excl. packaging):	242 kg (without weight stack) 305 kg / 328 kg (with weight stack)

Maximum user weight (chin up bar):	150 kg
------------------------------------	--------

Weight Stack

Weight stack:	1 (150 / 200 lbs)
Weight plates:	14+1 / 19+1
Cable length:	211 cm ; 834 cm ; 1098 cm
Cable material:	Steel
Cable coating:	Nylon
Pulley diameter:	90 mm ; 114 mm
Transmission ratio (press bar):	1:1
Transmission ratio (cable on one side):	2:1

1.2 Personal Safety

DANGER

- + Before you start using the equipment, you should consult your physician that this type of exercise is suitable for you from a health perspective. Particularly affected are persons who: have a hereditary disposition to high blood pressure or heart disease, are over the age of 45, smoke, have high cholesterol values, are overweight and/or have not exercised regularly in the past year. If you are under medical treatment that affects your heart rate, medical advice is absolutely essential.
- + Note that excessive training can seriously endanger your health. Please also note that heart rate monitoring systems can be inaccurate. If you notice any signs of weakness, nausea, dizziness, pain, shortness of breath, or other abnormal symptoms, stop exercising immediately and seek advice from your doctor if necessary.

WARNING

- + This equipment may not be used by children under the age of 14.
- + Children should not be allowed unsupervised access to the equipment.
- + Persons with disabilities must have a medical license and must be under strict observation when using the equipment.
- + The equipment is strictly for use by one person at a time.
- + If your equipment provides a safety key, the clip of the safety key must be attached to your clothing before starting your training. In the event of a fall, the EMERGENCY STOP of the equipment can be initiated.
- + Keep your hands, feet and other body parts, hair, clothing, jewellery and other objects well clear of moving parts.
- + During use, wear suitable sports clothing rather than loose or baggy clothing. When wearing sports shoes, make sure they have suitable soles, preferably made of rubber or other non-slip materials. Shoes with heels, leather soles, studs or spikes are unsuitable. Never exercise barefoot.

CAUTION

- + If your equipment needs to be connected to the power supply with a mains cable, make sure that the cable is not a potential tripping hazard.
- + Make sure that nobody is within the range of motion of the equipment during training so as not to endanger you or other persons.

ATTENTION

- + Do not insert any objects of any kind into the openings of the device.

1.3 Set-Up Place

WARNING

- + Do not place the equipment in main corridors or escape routes.

CAUTION

- + Choose a location in which to place the equipment such that there is enough free space/clearance to the front, the rear and to the sides of the equipment.
- + The training room should be well ventilated during training and not be exposed to any draughts.
- + Choose the place in which to set up the equipment such that there is enough free space/clearance to the front, the rear and to the sides of the equipment.
- + The set-up and mounting surface of the equipment should be flat, loadable and solid.
- + If your device is to be mounted on the wall/ceiling, make sure that you use the appropriate assembly material to avoid possible damages or personal injuries. The contractual partner accepts no liability for this.

ATTENTION

- + The device may only be used in one building, in sufficiently tempered and dry rooms (ambient temperatures between 10°C and 35°C). The equipment should not be used outdoors or in rooms with high humidity (over 70%) like swimming pools.
- + A floor protective mat/equipment underlay can help to protect high-quality floor coverings (parquet, laminate, cork, carpets) from dents and sweat and can help to level out slight unevenness.

2.1 General Instructions



DANGER

- + Do not leave any tools, packaging materials such as foils or small parts lying around, as otherwise there is a danger of suffocation for children. Keep children away from the equipment during assembly.



WARNING

- + Pay attention to the instructions attached to the equipment in order to reduce the risk of injuries.



CAUTION

- + Ensure to have sufficient room for movement in each direction during assembly.
- + The assembly of the equipment must be carried out by at least two adults. If in doubt, seek the help of a third technically skilled person.



ATTENTION

- + To prevent damage to the equipment and the floor, assemble the equipment on a mat or packaging board.



NOTICE

- + In order to make the assembly as simple as possible, some screws and nuts to be used can already be pre-assembled.
- + Ideally, assemble the equipment at its later set-up place.

2.2 Scope of Delivery

The scope of delivery consist of the following parts. At the beginning, check whether all parts and tools belonging to the device are included in the scope of delivery and whether damage has occurred. In the event of complaints, the contractual partner must be contacted directly.

⚠ CAUTION

If parts of the scope of delivery are missing or damaged, the assembly must not be carried out.

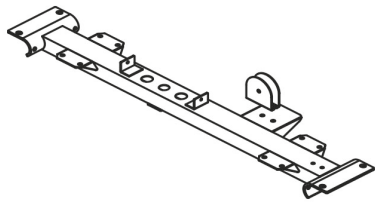

(1) BASE FRAME

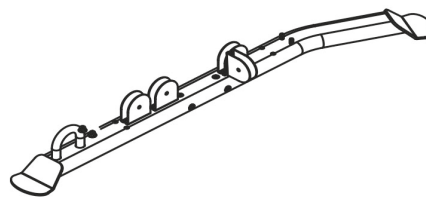

(2R) RIGHT BASE LEG

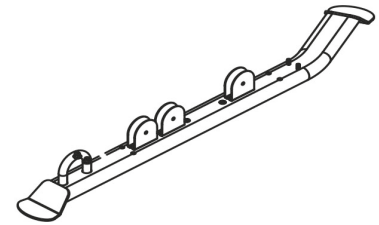

(3L) LEFT BASE LEG



**(4) HOLLOW
GUIDE
ROD X 2pcs**



**(5) MAIN
UPRIGHT FRAME
& (54) WEIGHT
CABLE X 2pcs**



**(6) UPRIGHT
FRAME**



**(7R) FRONT RIGHT
UPRIGHT FRAME**



**(8L) FRONT LEFT
UPRIGHT FRAME**



**(9R) REAR RIGHT
UPRIGHT FRAME**



**(10L) REAR LEFT
UPRIGHT FRAME**



**(11) 25mm X
1945mm SOLID
LINEAR GUIDE
ROD X 2pcs**

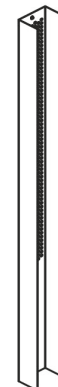

**(12R) RIGHT
WEIGHT
SHROUD**

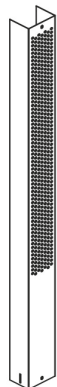

**(12L) LEFT
WEIGHT
SHROUD**

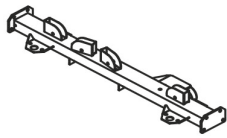

(13) TOP FRAME

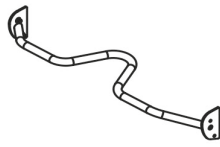

(14) CHIN-UP BAR

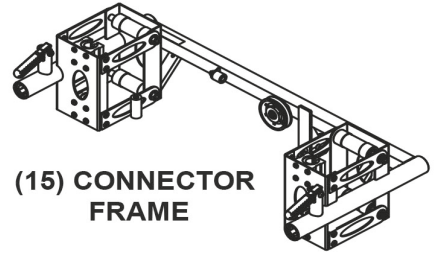

(15) CONNECTOR FRAME



(17) TOP GUIDE ROD HOLDER

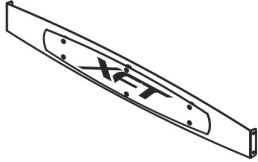

(16) PANEL & (16A) LOGO PANEL



(19R) RIGHT PULLEY HEIGHT ADJUSTER



(20L) LEFT PULLEY HEIGHT ADJUSTER



(26) STACK SPACER X 2pcs

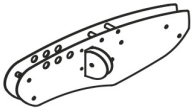

(22R) RIGHT TOP PANEL



(23L) LEFT TOP PANEL

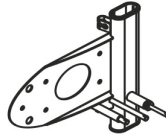

(24) ADJUSTER FRAME



(25) ADJUSTMENT FRAME



(27) PRESS BAR



(28) LONG BAR



(29) SPORT BAR



(31) 25mm X 1100mm SOLID LINEAR GUIDE ROD X 2pcs



(36) DOUBLE PULLEY BLOCK X 2pcs



(38) TOP PLATE



(37) PULLEY BLOCK



(39) WEIGHT PLATE X 14pcs (19pcs with upgrade)



(40) SELECTOR ROD



(41) ANKLE STRAP

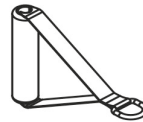

(42) SINGLE HANDLE X 2pcs



(43) CHAIN X 2pcs



(51) 114mm PULLEY X 3pcs



(52) 90mm PULLEY X 33pcs



(60) SELECTOR PIN



(68) SNAP HOOK X 2pcs



(72) PLASTIC GUIDE ROD HOLDER X 2pcs

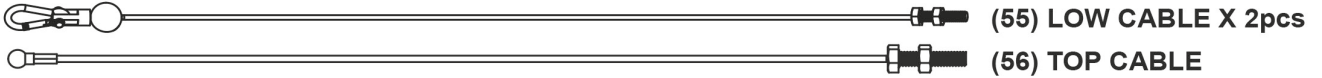

(55) LOW CABLE X 2pcs

(56) TOP CABLE

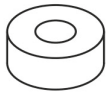

(74) 64mm RUBBER CUSHION X 2pcs



(75) 48mm RUBBER CUSHION X 6pcs



(75A) 61mm RUBBER CUSHION X 2pcs



(78) STEEL COLLAR X 2pcs



(90) 1/2" STOPPER X 2pcs



(140) 30 X 60mm OVAL PLUG



(141) TRICEP ROPE

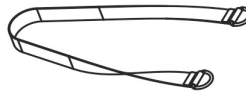

(142) CHIN ASSIST STRAP

NO.	DESCRIPTION	QTY.
94	3/8" X 3-1/8" HEX BOLT	12
95	3/8" X 3" HEX BOLT	6
96	3/8" X 2-1/4" HEX BOLT	5
98	3/8" X 1-3/4" HEX BOLT	25
100	3/8" X 1" HEX THREADED BOLT	16
103	TOP PLATE BOLT	1
107	5/16" X 1/4" ROUND SCREW	4
118	3/8" WASHER	70
119	5/16" WASHER	4
131	3/8" NYLON NUT	64
138	M5 HEX WRENCH	1
139	M4 HEX WRENCH	1
157	M2.5 HEX WRENCH	1

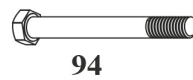

94



100



118



131

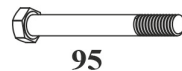

95



103



119

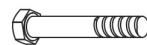

96



107

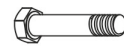

98



138



139



157

2.3 Assembly

Before assembly, take a close look at the individual assembly steps shown and carry out the assembly in the order given.

① NOTICE

First loosely screw all parts together and check that they fit properly. Tighten the screws using the tool only when you are instructed to do so.

Step 1: Assembly of the Base Legs and Base Frame

① NOTICE

Make sure to align the base legs and base frame correctly, so the pulley holder is facing the rear side.

1. Attach the right base leg (2R) to the base frame (1) with two bolts (93) and two spring washers (120) as well as two bolts (100) and two spring washers (121).
2. Attach the left base leg (3L) to the base frame (1) with two bolts (93) and two spring washers (120) as well as two bolts (100) and two spring washers (121).
3. Tighten all bolts by beginning with the bolts (100).

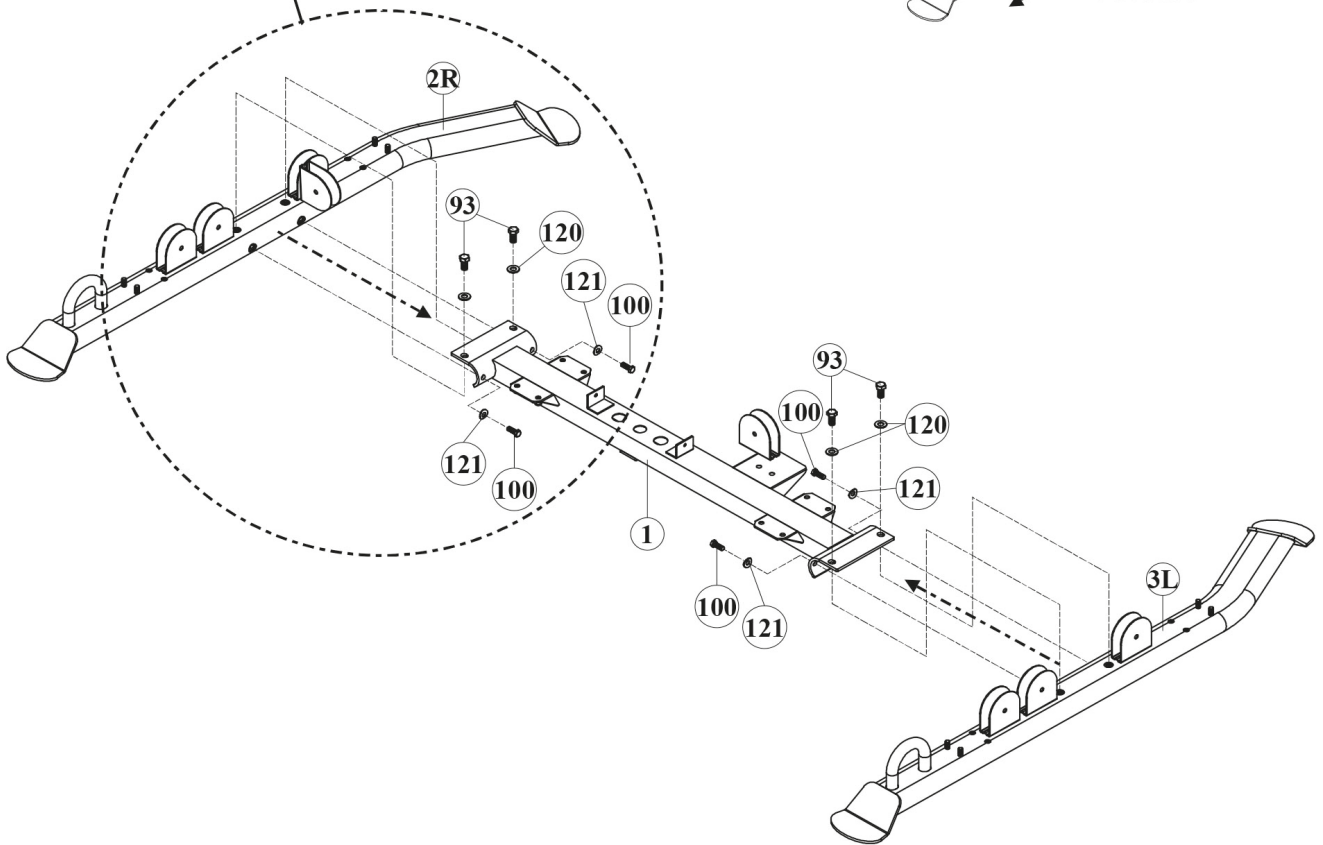
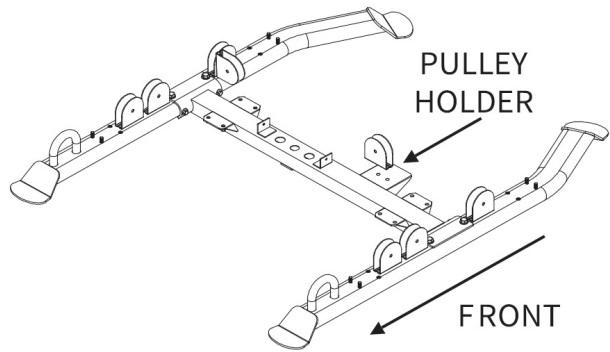
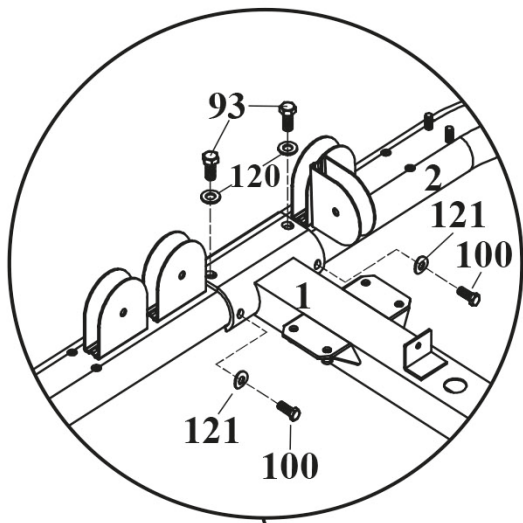

Step 2: Assembly of the Main Upright Frames, Part 1

1. Attach one oval plug (140) to the connector frame (15).

① NOTICE

- + Please note that the following step must be carried out for both main upright frames (5), even though only one is shown.
 - + Do not tighten the screws completely until instructed to.
2. Remove the pre-assembled bolt (A) and washer (B) that secure the weight cable from both main upright frames (5).
 3. Loosely attach one of the main upright frames (5) to the base frame (1) with four bolts (100), eight washers (118) and four nylon nuts (131). Make sure the guide rod holder is facing the front like shown.
 4. Remove eight bolts (122) from the connector frame (15) [fig. 1].
 5. Rotate the four steel plates (44) like shown in figure 2.
 6. Attach the connector frame (15) to the main upright frame (5).

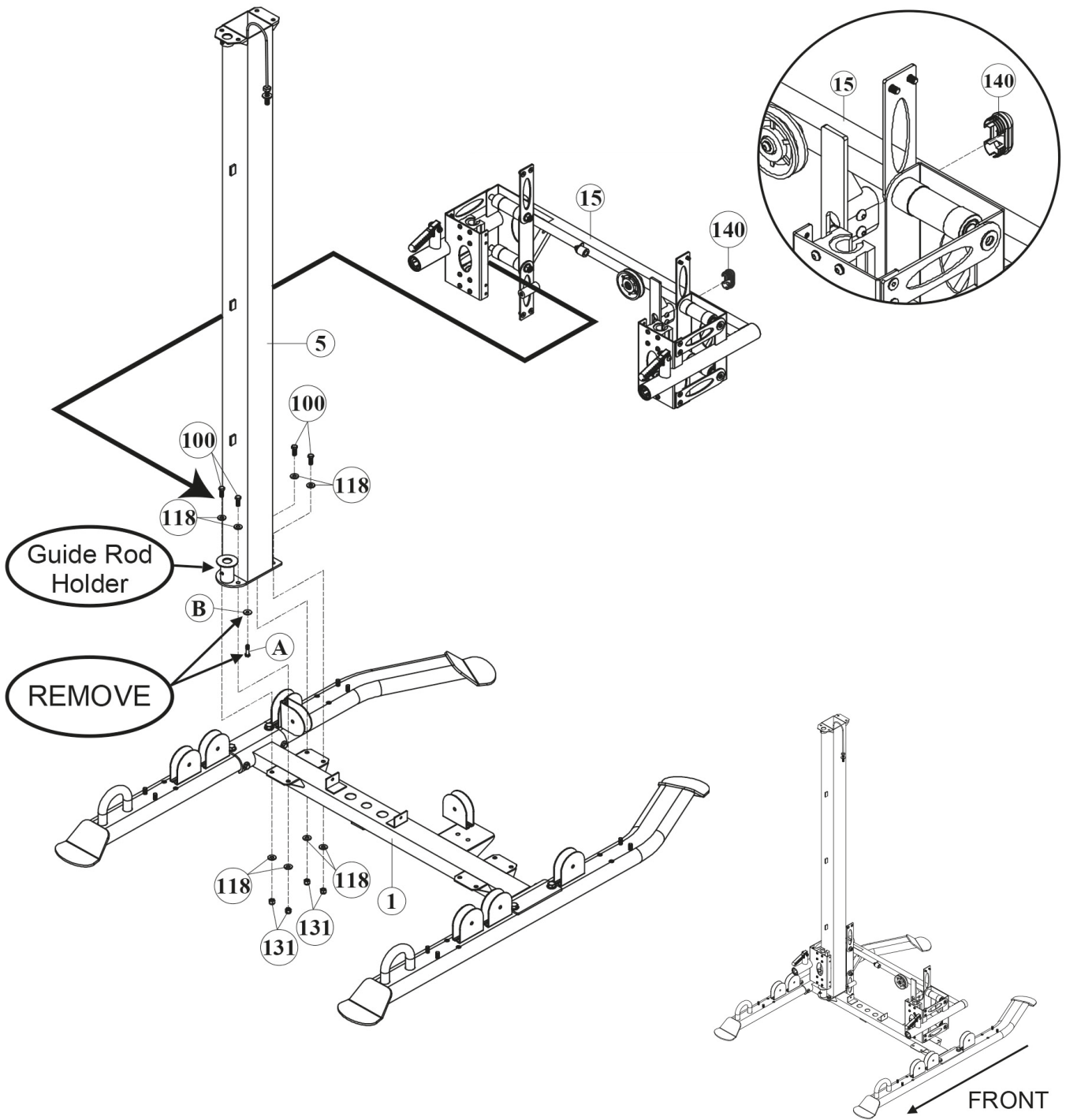
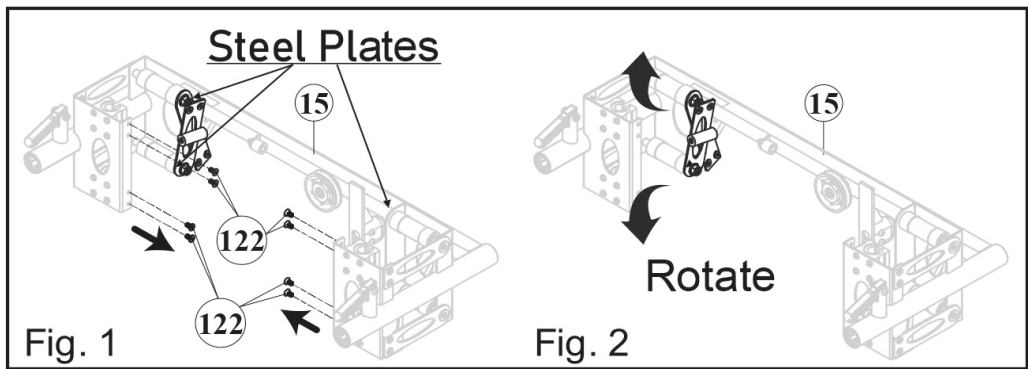

Step 3: Assembly of the Main Upright Frames, Part 2

ⓘ NOTICE

Do not tighten the screws completely until instructed to.

1. If not already done in the previous step, remove the pre-assembled bolt (A) and washer (B) from the second main upright frame (5).
2. Insert the main upright frame (5) to the base frame (1) and slide the main upright frame (5) to the other side of the connector frame (15) [fig.2].
3. Loosely attach the main upright frame (5) to the base frame (1) with four bolts (100), eight washers (118) and four nylon nuts (131) [fig. 1].
4. Rotate the steel plates (44) back to their intended positions and secure with the eight previously removed bolts (122) [fig. 3].

Fig. 1

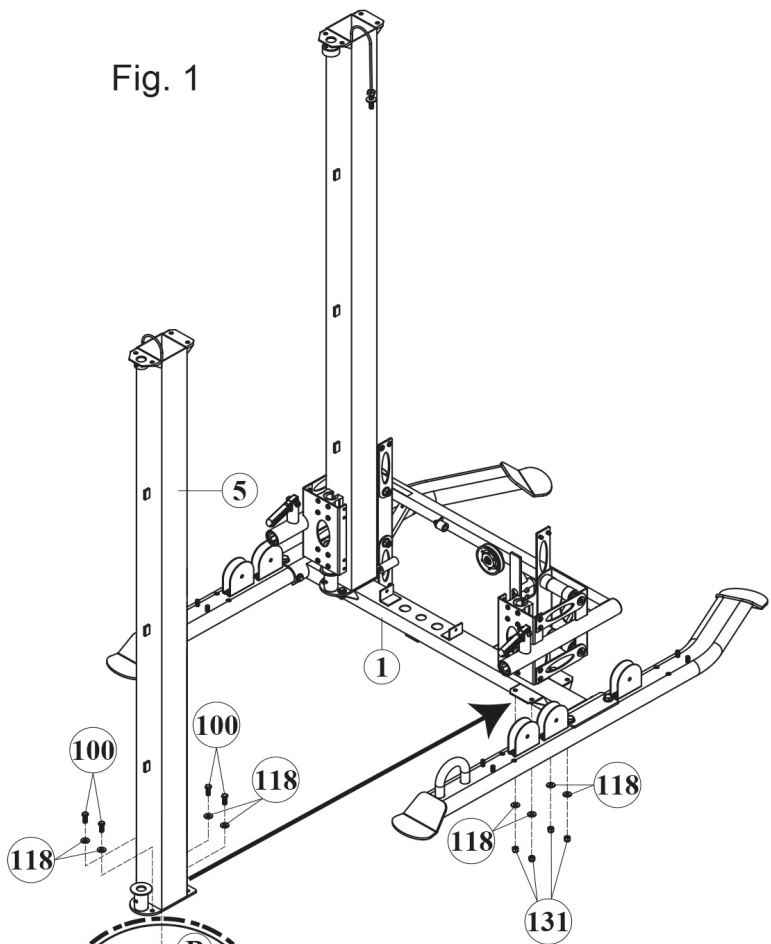

Fig. 2

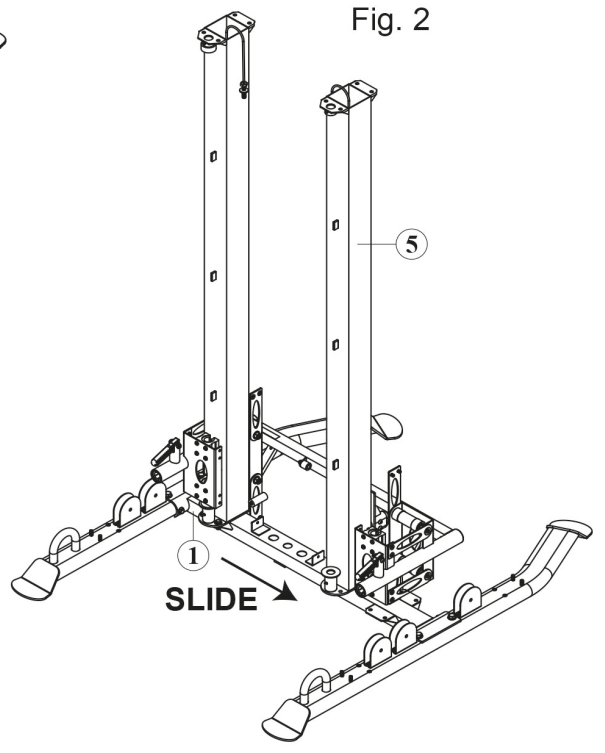
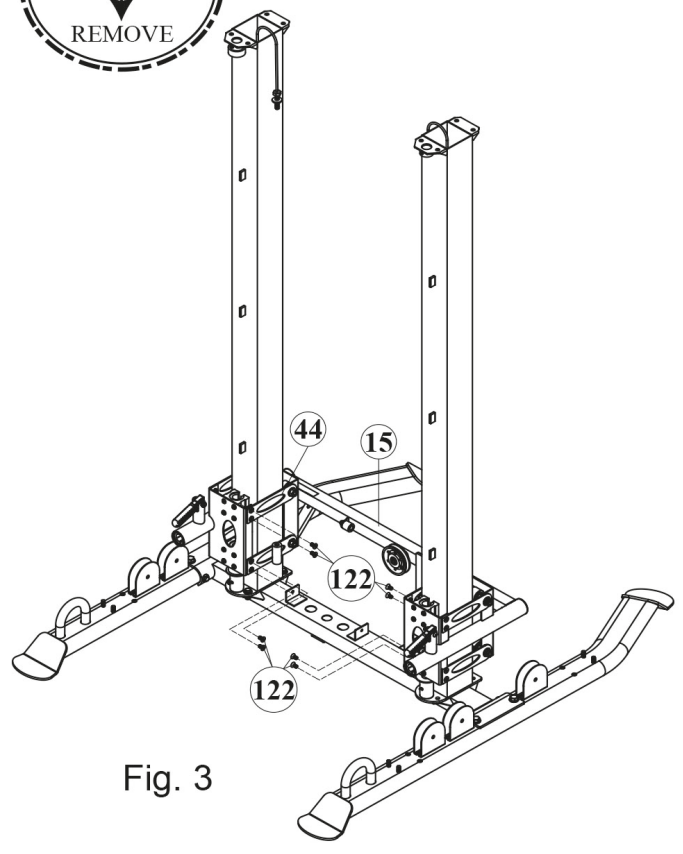

Fig. 3



Step 4: Assembly of the Top Frame

ⓘ NOTICE

Do not tighten the bolts completely until instructed to.

1. Place the top frame (13) onto the main upright frames (5) by pulling the weight cables (54) through the the outer pulley holders as shown in figure 1.
2. Loosely attach the top frame (13) to the main upright frames (5) with a total of eight bolts (100), 16 washers (118) and eight nylon nuts (131).
3. Route each weight cable (54) over one 90 mm pulley (52).
4. Now attach each pulley (52) to the top frame (13) with one bolt (98) and one nylon nut (131) each [fig. 2].

ⓘ NOTICE

When completed, the weight cables (54) should be facing downwards through the top frame (13).

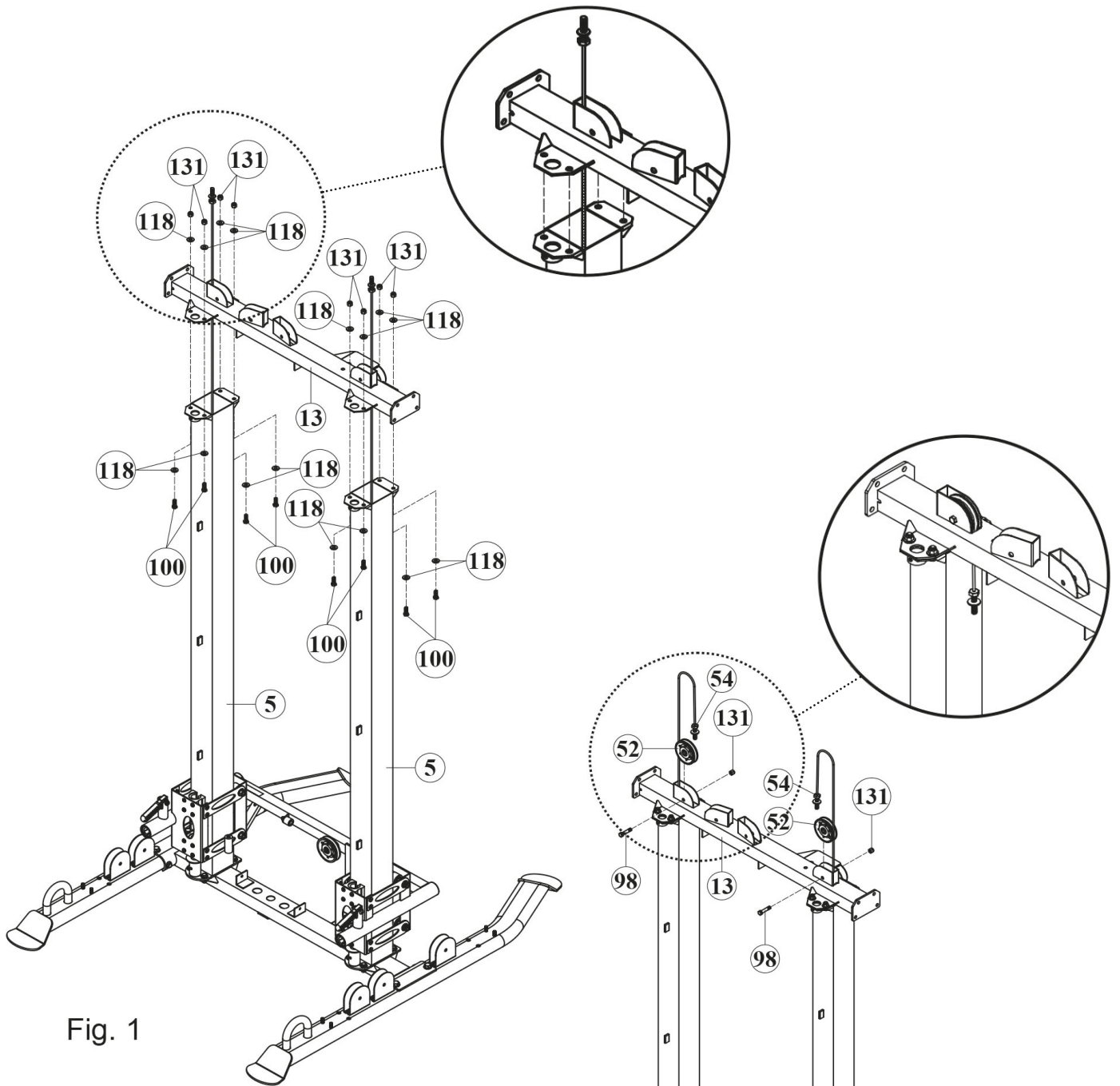

Fig. 1

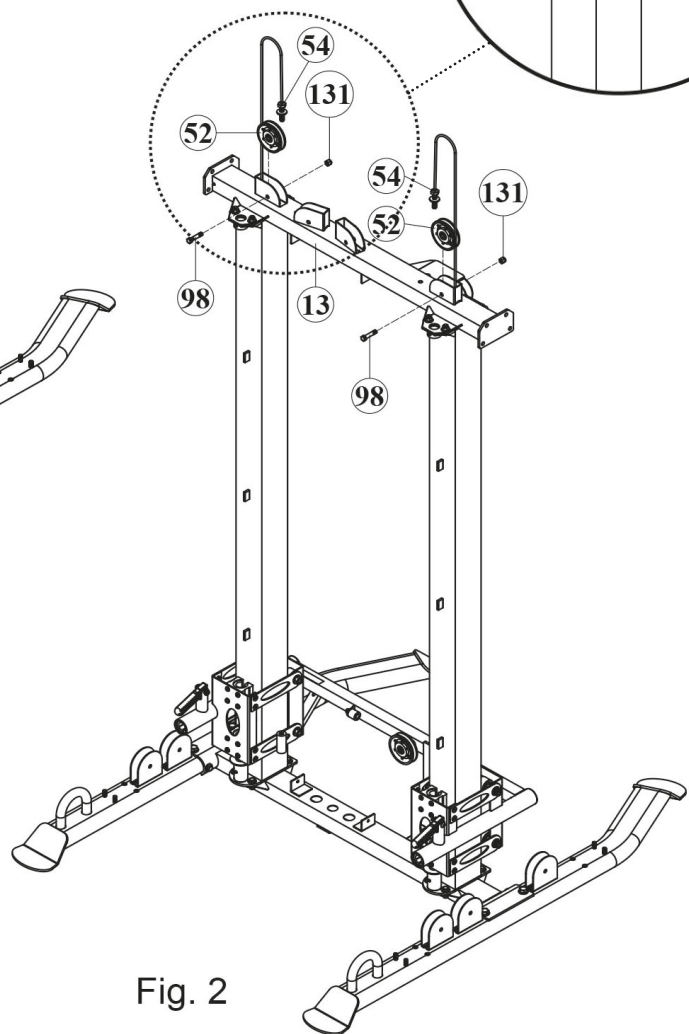

Fig. 2

Step 5a: Assembly of the Vertical Guide Rods (Normal/High Ceiling Height)

► ATTENTION

This assembly step requires a ceiling height of 95" or approximately 241 cm. If you have a lower ceiling height of 84.5" or approximately 214 cm, skip this step and proceed to step 5b instead.

1. Slide one 48mm rubber cushion (75) onto the upper portion of one solid linear guide rod (11).
2. Place another 48mm rubber cushion (75) onto the lower rod holder [fig. 2].
3. Loosen the top and bottom screws (116).
4. While holding the solid linear guide rod (11) at a slight angle, slide the top of the solid linear guide rod (11) up through the upper rod holder. The bottom of the solid linear guide rod (11) should be just above the connector frame (15) [fig. 3].
5. Align the bottom of the solid linear guide rod (11) with the linear bearing on the connector frame (15).
6. Carefully and slowly lower the solid linear guide rod (11) through the linear bearing and the 48mm rubber cushion (75) and into the lower rod holder.
7. Retighten the screws (116).
8. Repeat the steps 1 to 7 on the other side.

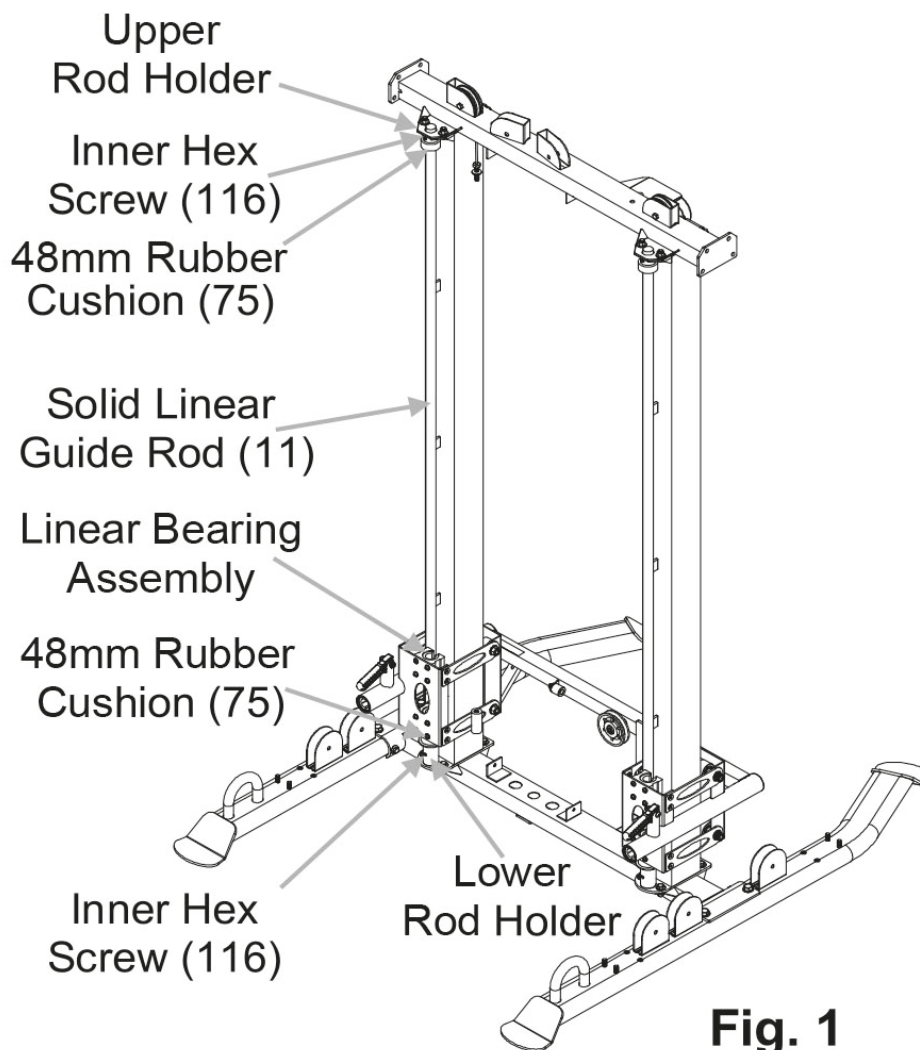

Fig. 1

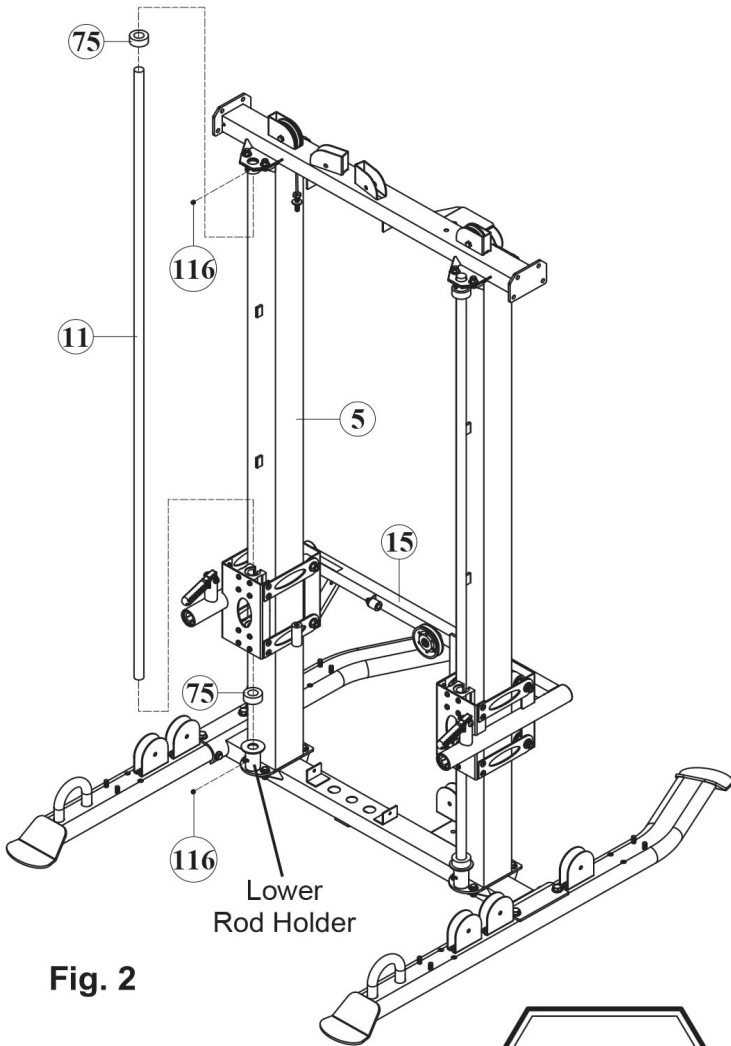

Fig. 2

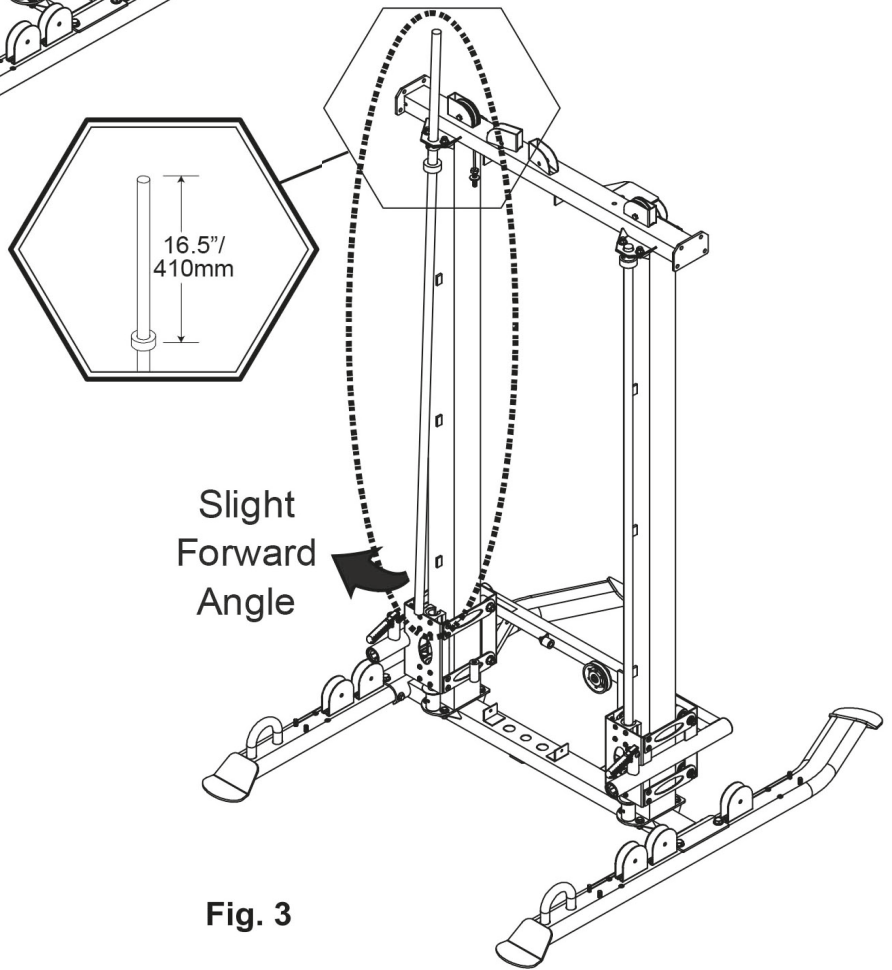

Fig. 3

Step 5b: Assembly of the Vertical Guide Rods (Low Ceiling Height)

► ATTENTION

This step is for lower ceiling heights. If you completed step 5a, skip this step and proceed to step 6 instead.

1. Remove the two linear bearing cartridges from the connector frame (15) by removing eight screws (109) and eight spring washers (124) [fig. 1].
2. Remove four bolts (122) from the connector frame (15) and rotate the steel plates (44) [fig. 1.1].
3. Repeat the step 1 and 2 for the other side.
4. Carefully and slowly slide two linear bearing cartridges and one 48mm rubber cushion (75) onto the solid linear guide rod (11) [fig. 2.1].
5. Place another 48mm rubber cushion (75) onto the lower rod holder.
6. Loosen the top and bottom screws (116).
7. While holding the solid linear guide rod (11) at a slight angle, slide the top of the solid linear guide rod (11) up through the upper rod holder.
8. Then carefully lower the solid linear guide rod (11) through the 48mm rubber cushion (75) and into the lower rod holder.
9. Reattach the linear bearing cartridges to the connector frame (15) using the previously removed screws (109) and spring washers (124).
10. Rotate the steel plates (44) back into position and secure with the previously removed bolts (122).
11. Repeat the steps 4 to 10 for the other side.
12. Secure both solid linear guide rods (11) by retightening the screws (116).

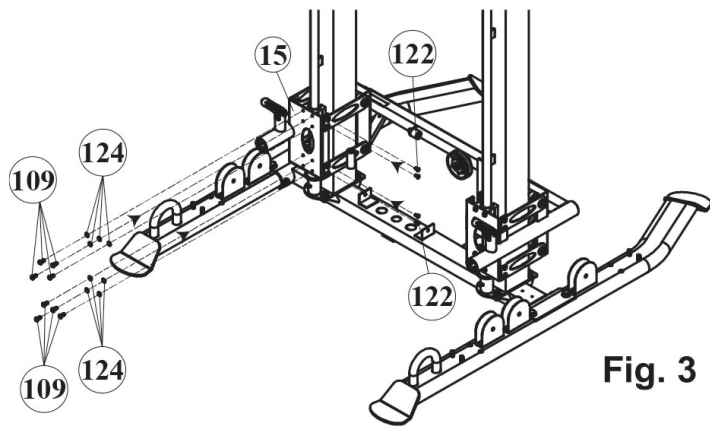
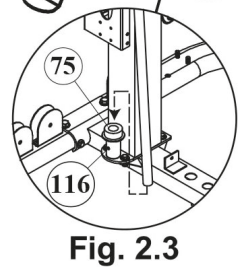
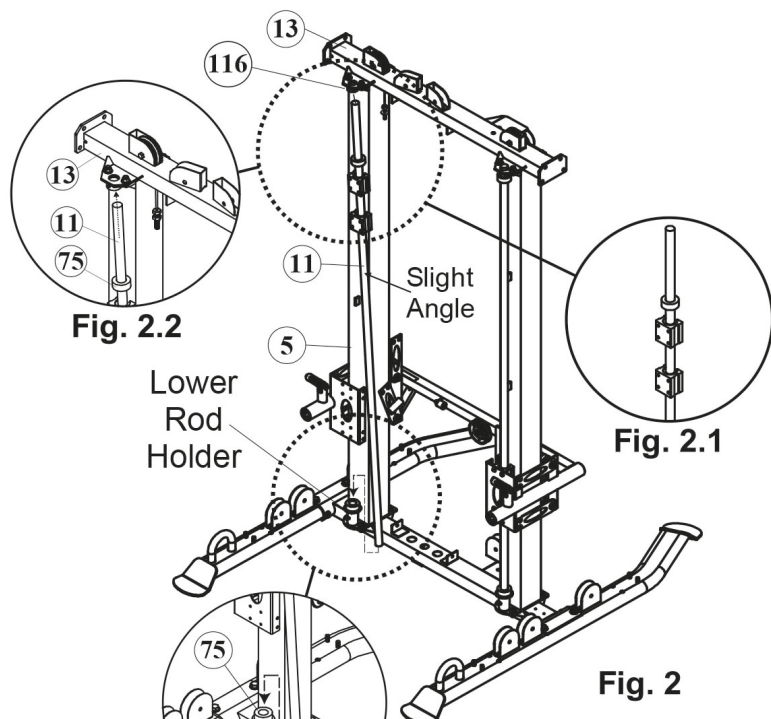
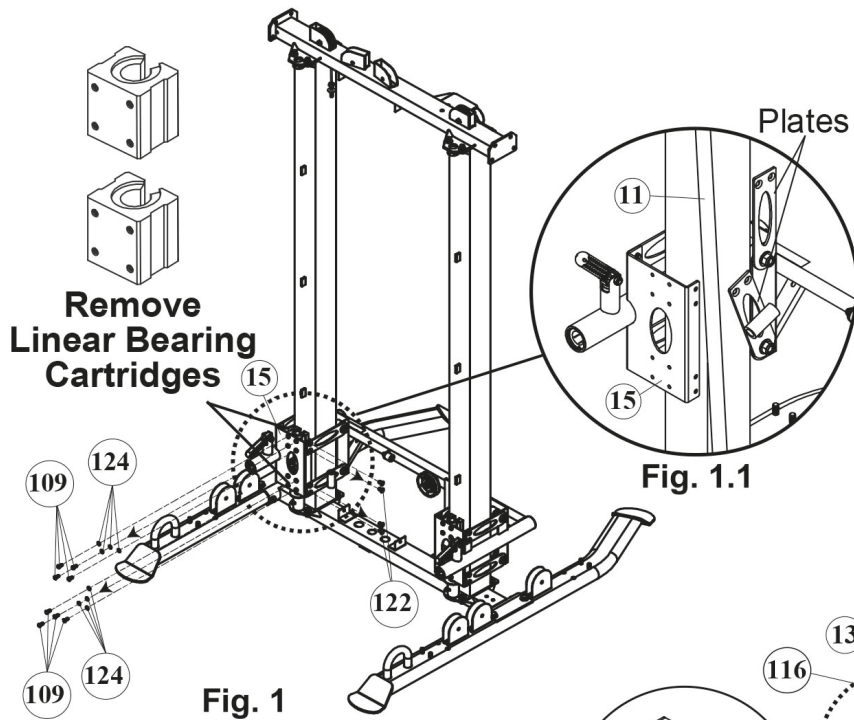

Step 6: Assembly of the Weight Cables

 **WARNING**

When pulling down the bolt end of the weight cable (54), be aware that it is very heavy. Carry out this step only with another person.

1. Attach each of the bolt ends of the pre-assembled weight cables (54) to the right and left side of the steel plates (44) by pulling down the weight cable.
2. Thread the bolt of the weight cable (54) together with a spring washer (120) into the steel plate.

 **WARNING**

The bolt must be tightened completely.

3. Repeat the steps for the other side.

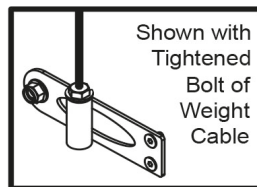
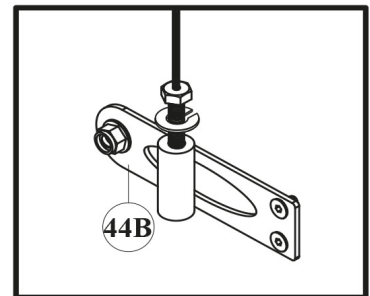
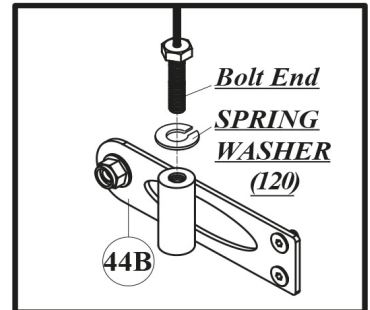
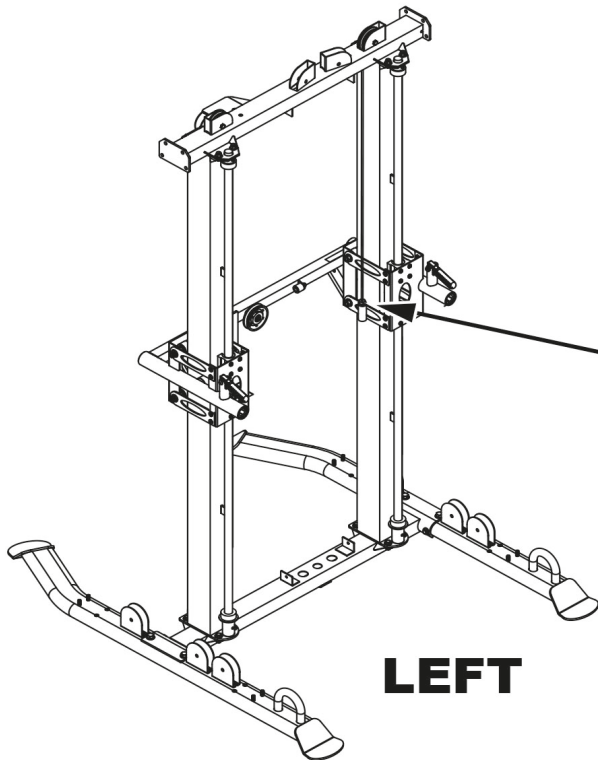
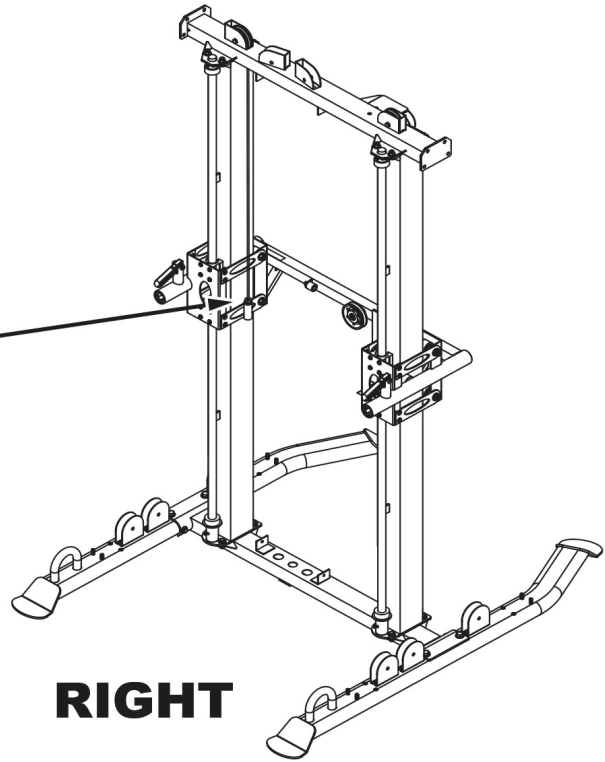
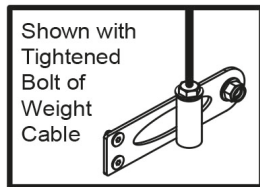
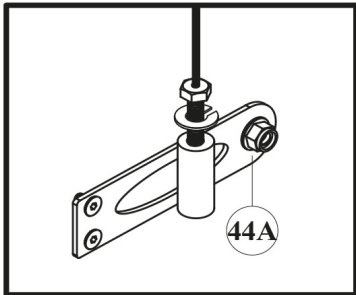
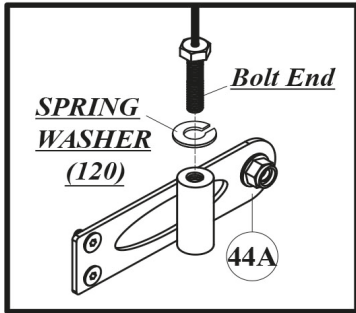

Step 7: Checking the Connector Frame

① NOTICE

This step is to ensure that the connector frame (15) runs smoothly.

1. Move the connector frame (15) up and down the main upright frames (5) a few times. You should be able to easily move the connector frame (15).
2. Temporarily place the connector frame (15) at mid-height.
3. Tighten the four bolts (100) and four nylon nuts (131) at the bottom of each main upright frame (5).
4. Tighten the four bolts (100) and four nylon nuts (131) at the top of each main upright frame (5).
5. Now you can slide the connector frame (15) back down.

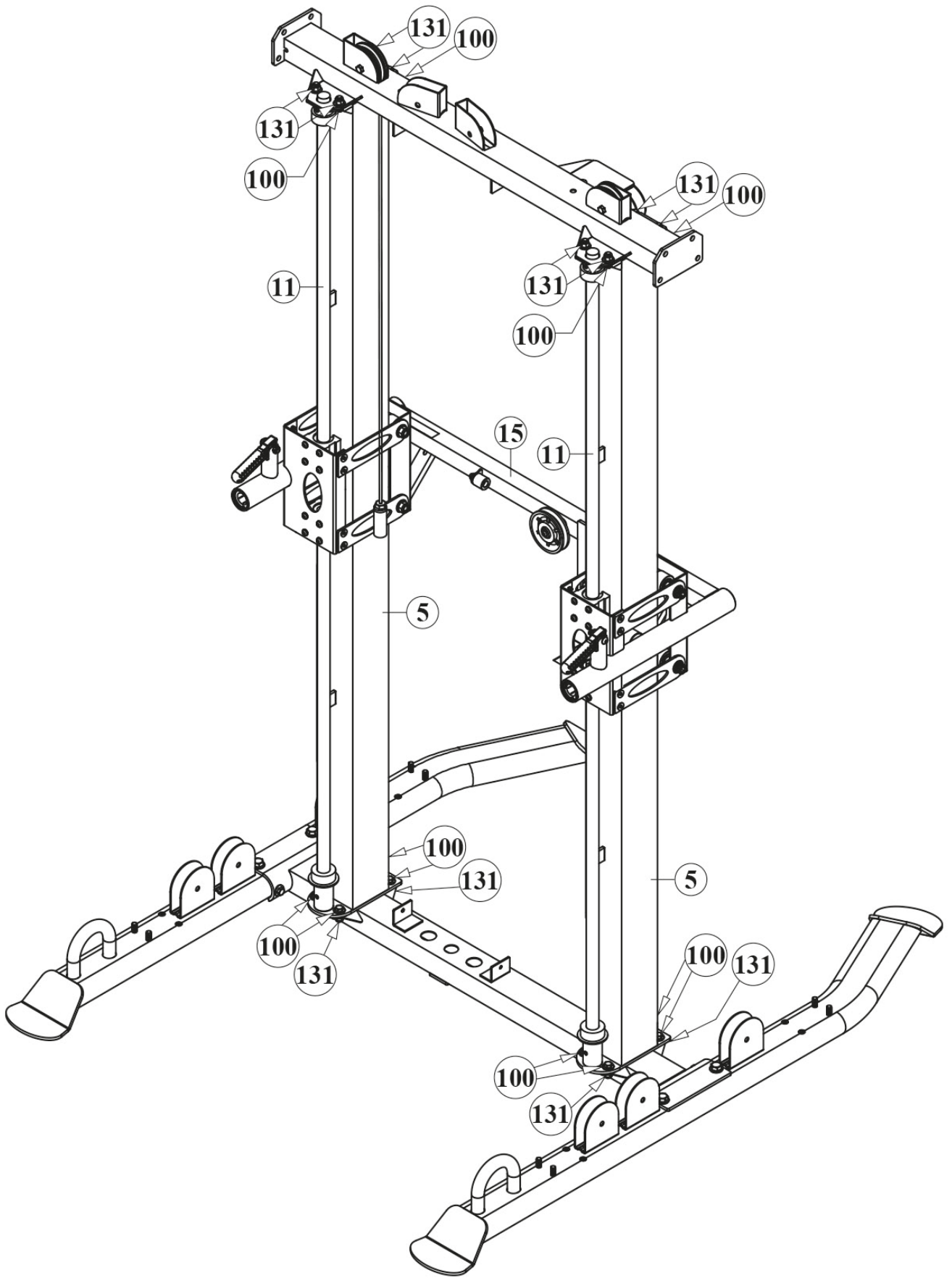

Step 8: Assembly of the Front and Rear Upright Frames

ⓘ NOTICE

Do not tighten the screws completely until instructed to.

1. Loosely attach the front right and front left upright frames (7R & 8L) to the right and left base legs (2R & 3L) with two screws (145), two spring washers (146), two washers (118) and two nylon nuts (131) each.
2. Loosely attach the rear right and rear left upright frames (9R & 10L) to the right and left base legs (2R & 3L) with two screws (145), two spring washers (146), two washers (118) and two nylon nuts (131) each.

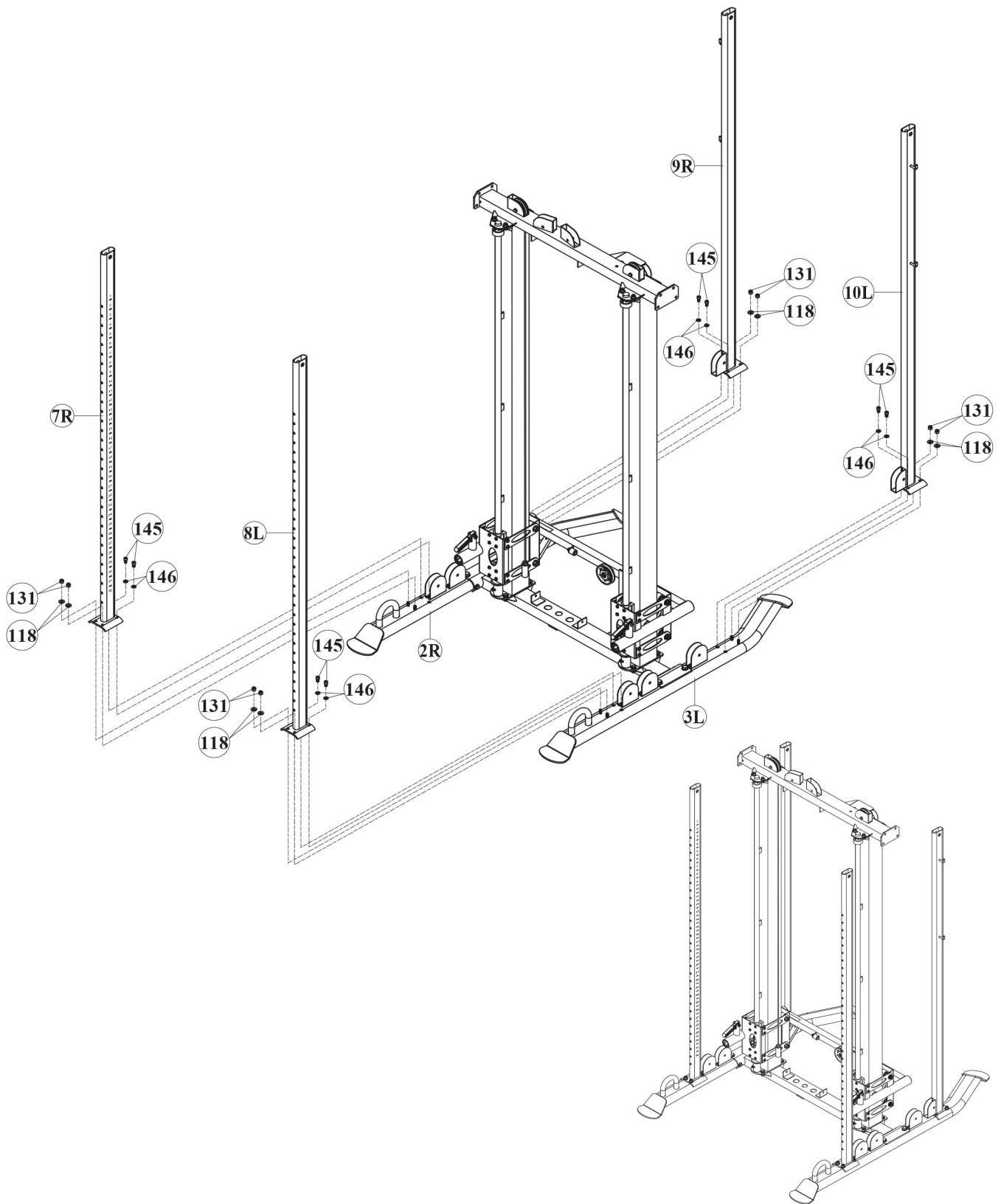

Step 9: Assembly of the Top Panel

ⓘ NOTICE

Do not tighten the bolts completely until instructed to.

1. Slide the right pulley height adjuster (19R) onto the front right upright frame (7R) by pulling the pop-pin. Make sure the number gauge opening is facing inwards.
2. Repeat the process with the left pulley height adjuster (20L) and the front left upright frame (8L).
3. Slide the right top panel (22R) onto the right front and rear upright frames (7R & 9R).
4. Loosely attach the right top panel (22R) to the top frame (13) with four bolts (94), four washers (118) and four nylon nuts (131).
5. Loosely attach the right top panel (22R) to the rear right upright frame (9R) with one bolt (95), two washers (118) and one nylon nut (131).
6. Repeat the steps 3 to 5 with the left top panel (23L) and the left front and rear upright frames (8L & 10L).

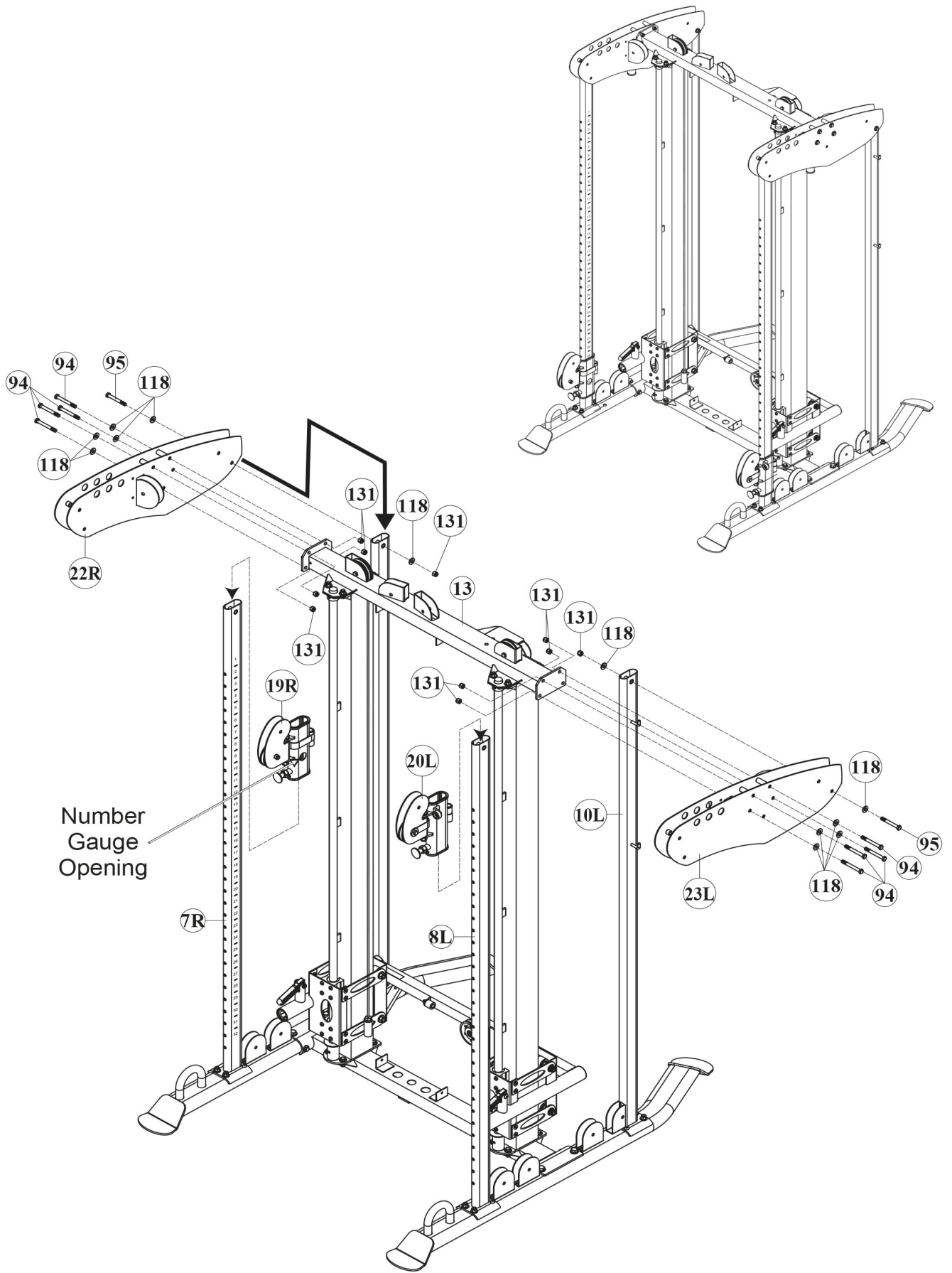

Step 10: Assembly of the Guide Rods and Weight Stack

NOTICE

If you have purchased the version with 19 weight plates (200 lbs), do not install the two stack spacers (26). Only install the stack spacers (26) if you have purchased the version with 14 weight plates (150 lbs).

1. Attach the selector rod (40) to the top plate (38) with one top plate bolt (103).
2. Tighten the top plate bolt (103).
3. Insert two plastic guide rod holders (72) into the base frame (1).
4. Insert both hollow guide rods (4) into the plastic guide rod holders (72) and base frame (1).

ATTENTION

+ Step 5 must only be carried out if you have the 150 lbs weight stack with 14 weight plates. If you have the heavier weight stack, skip step 5 and proceed directly to step 6.

+ It is recommended to perform the following steps with two people.

5. Slide one stack spacer (26) over each of the hollow guide rods (4).
6. Slightly angle the hollow guide rods (4) forward like shown in the bottom left figure.
7. Slide one 64mm rubber cushion (74) over each of the hollow guide rods (4).
8. Carefully slide each of the 14 or 19 weight plates (39) over the hollow guide rods (4) one by one. Make sure to align the weight plates (39) so the selector holes are on the bottom and all weight plates facing forwards.
9. Carefully slide the top plate (38) with the assembled selector rod (40) over the hollow guide rods (4). Make sure the selector rod (40) goes through the center holes of the weight plates (39).
10. Place the top guide rod holder (17) onto the top of both hollow guide rods (4).
11. Carefully return the hollow guide rods (4) to the upright position.
12. Attach the top guide rod holder (17) to the top frame (13) with two round screws (106).
13. Tighten the hollow guide rods (4) with two screws (116).

150lb Stack

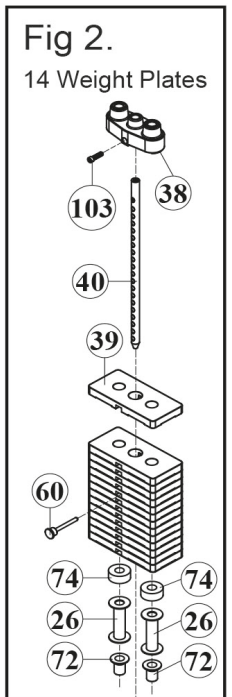

200lb Stack

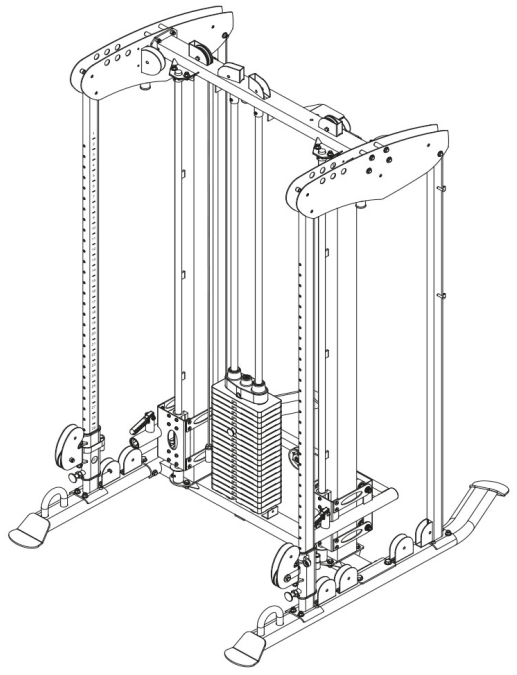
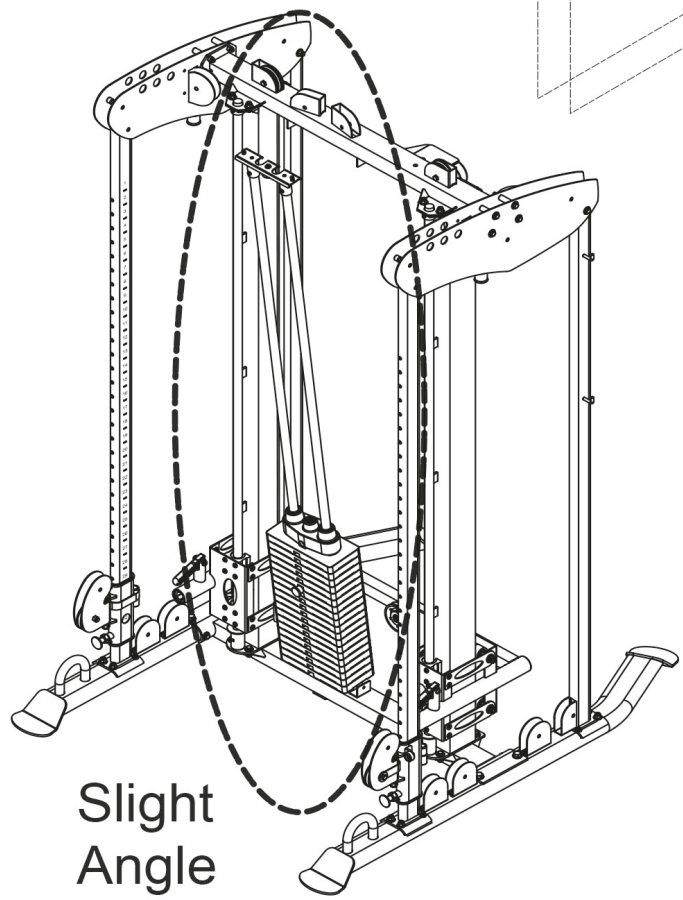
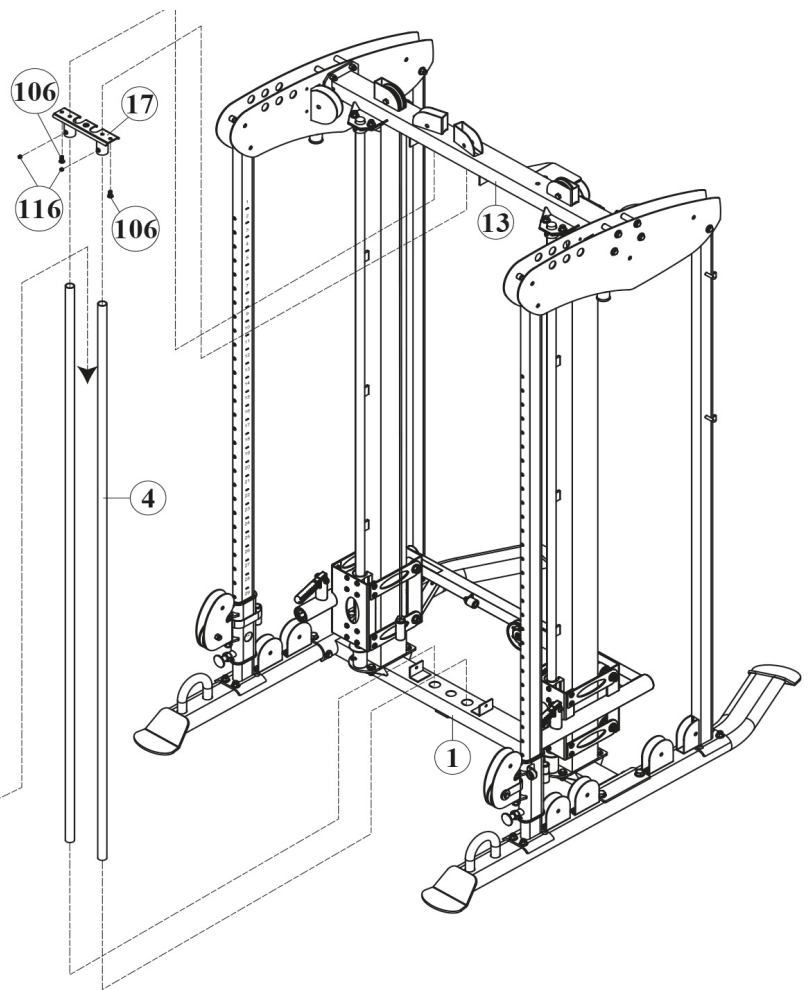
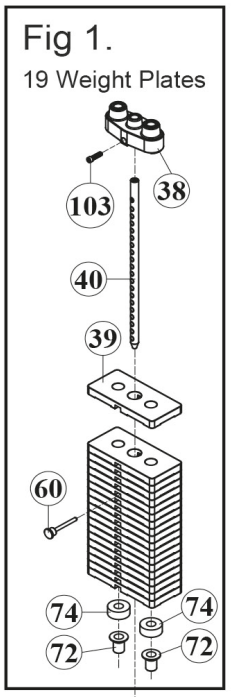

Step 11: Assembly of the Upright Frame, Adjuster Frame and Chin-up Bar

① NOTICE

Do not tighten the screws and bolts completely until instructed to.

1. Attach the adjustment lever (25) to the adjuster frame (24) with three screws (112), three 5mm tubes (151), six washers (126) and three nylon nuts (135).
2. Slide the adjuster frame (24) onto the upright frame (6) by engaging the adjustment lever (25) to release the pop-pin.
3. Attach the upright frame (6) to the base frame (1) and top frame (13) with a total of four bolts (104).
4. Attach the chin-up bar (14) and two 90mm pulleys (52) to the right and left top panel (22R & 23L) with a total of four bolts (94), eight washers (118) and four nylon nuts (131).
5. Now tighten all screws and bolts.

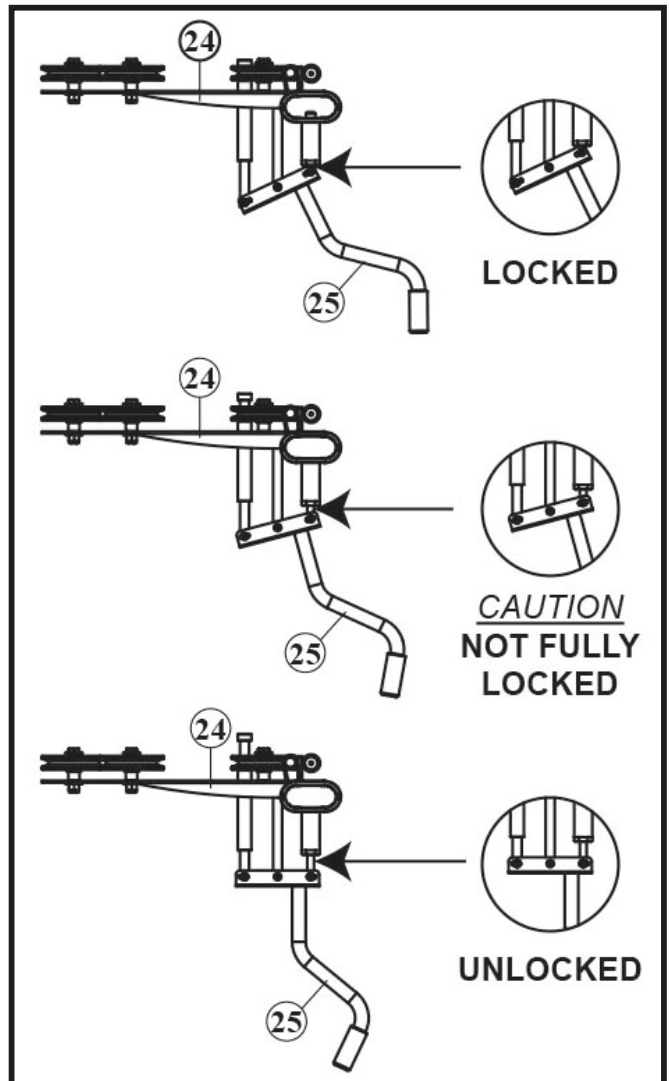

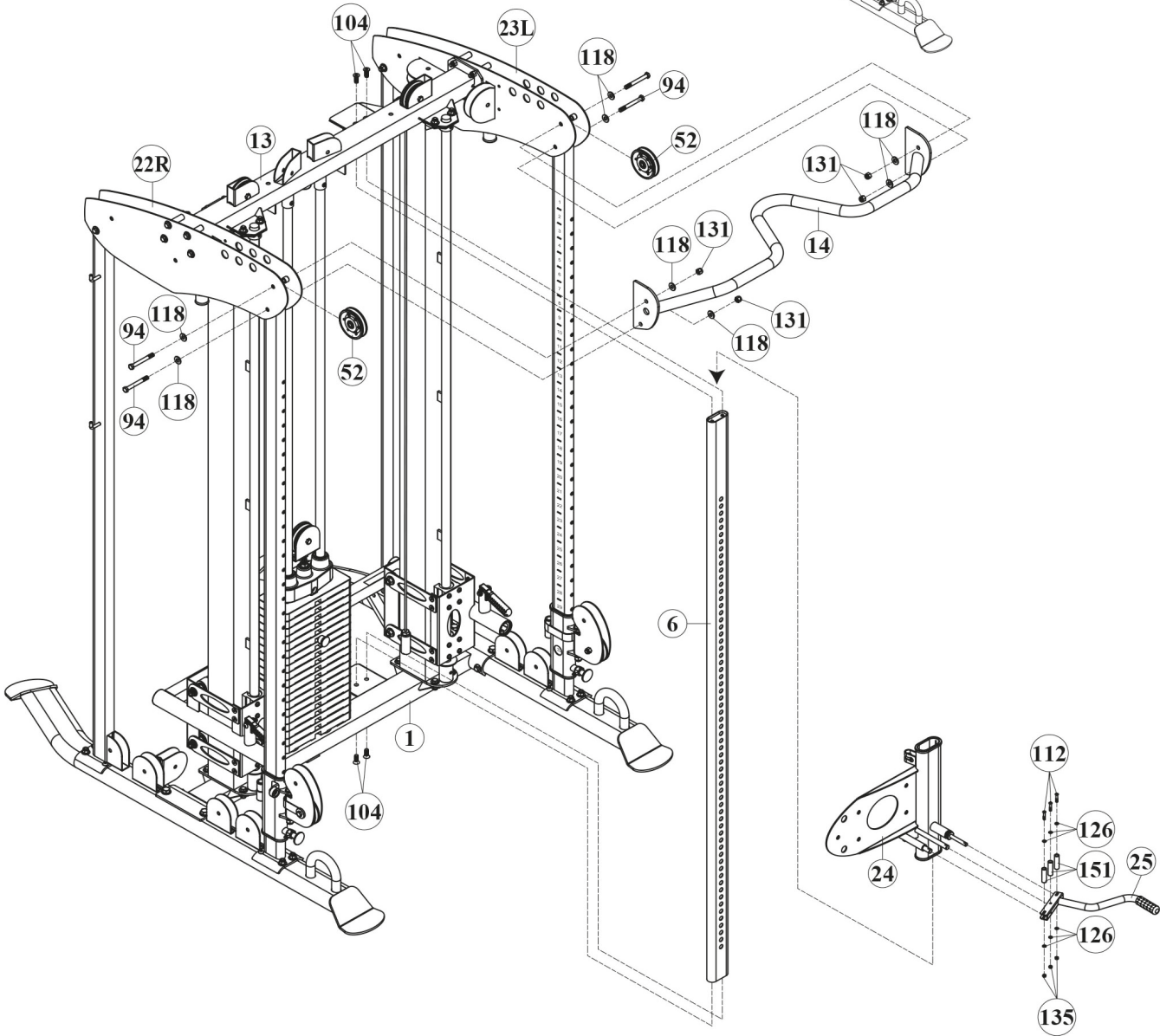
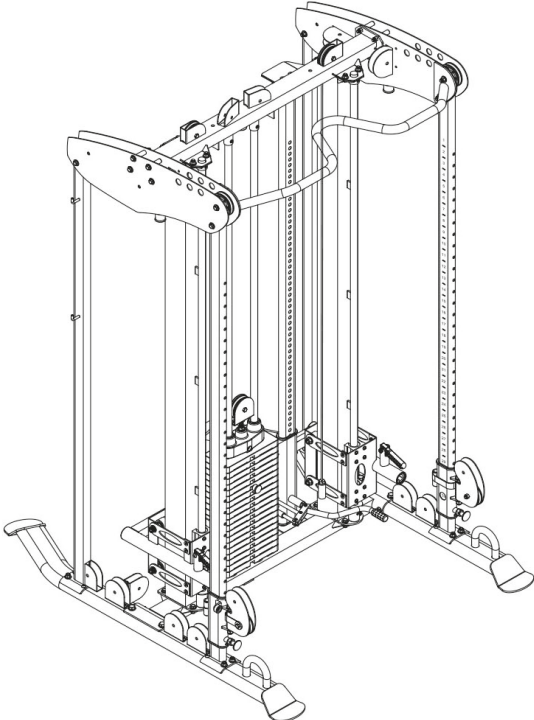

Step 12: Assembly of the Top Cable and Pulleys

NOTICE

- + Before proceeding with the cable routing, carefully study the cable routing overview beginning with T1.
- + Route the cable while simultaneously assembling the pulleys as you go.

1. Screw the bolt end of the top cable (56) into the adjuster frame (24) [T1].
2. Route the cable (56) over one 90mm pulley (52) and attach the pulley (52) to the top frame (13) with one bolt (98) and one nylon nut (131) [T2].
3. Route the cable (56) over one 114mm pulley (51) and attach the pulley (51) to the left top panel (23L) with one bolt (98) and one nylon nut (131) [T3].
4. Route the cable (56) through the left top panel (23L) and over one 90mm pulley (52) and attach the pulley (52) to the left top panel (23L) with one bolt (95), two washers (118) and one nylon nut (131) [T4].
5. Route the cable (56) under one 90mm pulley (52) and attach the pulley (52) to the top part of the double pulley block (36) with one bolt (98) and one nylon nut (131) [T5].
6. Route the cable (56) up and over one 114mm pulley (51) and attach the pulley (51) to the left top panel (23L) with one bolt (98) and one nylon nut (131) [T6].
7. Route the cable (56) over one 90mm pulley (52) and attach the pulley (52) to the top frame (13) with one bolt (98) and one nylon nut (131) [T7].
8. Place one nut (136) onto the top plate (38), then thread the pulley block (37) into the selector rod (40) at least 1/3. Route the cable (56) under one 90mm pulley (52) and attach the pulley (52) to the pulley block (37) with one bolt (98) and one nylon nut (131) [T8].
9. Route the cable (56) through the top frame (13) and over one 90mm pulley (52) and attach the pulley (52) to the top frame (13) with one bolt (98) and one nylon nut (131) [T9].
10. Route the cable (56) through the right top panel (22R) and over one 114mm pulley (51) and attach the pulley (51) to the right top panel (22R) with one bolt (98) and one nylon nut (131) [T10].
11. Route the cable (56) under one 90mm pulley (52) and attach the pulley (52) to the upper part of the double pulley block (36) with one bolt (98) and one nylon nut (131) [T11].
12. Route the cable (56) through the right top panel (22R) and over one 90mm pulley (52) and attach the pulley (52) to the top right panel (22R) with one bolt (95), two washers (118) and one nylon nut (131) [T12].
13. Route the cable (56) under one 90mm pulley (52) and attach the pulley (52) to the right base leg (2R) with one bolt (98) and one nylon nut (131) [T13].
14. Route the cable (56) under one 90mm pulley (52) and attach the pulley (52) to the base frame (1) with one bolt (98) and one nylon nut (131) [T14].
15. Route the cable (56) over two 90mm pulleys (52) and under one 90mm pulley (52) and attach the pulleys (52) to the adjuster frame (24) with one bolt (96), two washers (118) and one nylon nut (131) each [T15, T16, T17, T18].
16. Route the cable (56) under two 90mm pulleys (52) and attach the pulleys (52) to the adjuster frame (24) with one bolt (96), two washers (118) and one nylon nut (131) each [T19, T20].
17. Attach the steel ball end of the cable (56) to the adjuster frame (24) [T21].

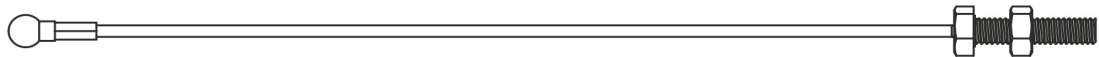

Steel Ball End

TOP CABLE (56)

Bolt End

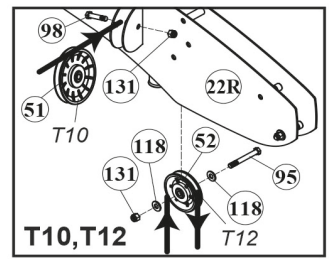
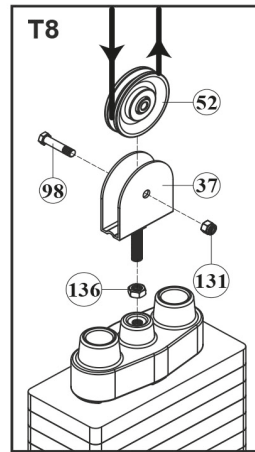
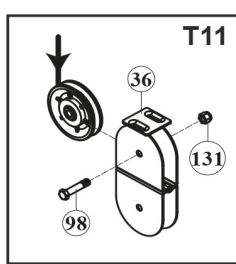
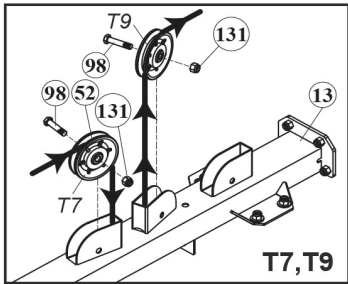
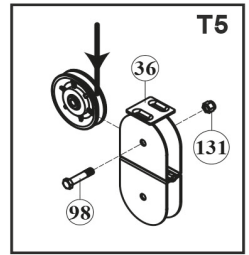
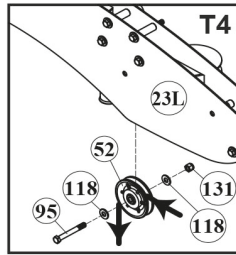
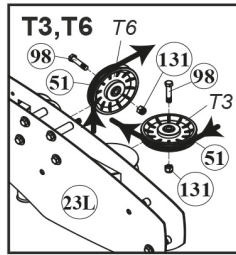
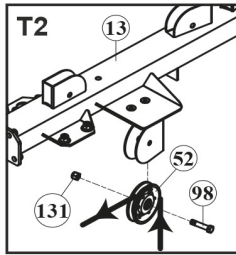
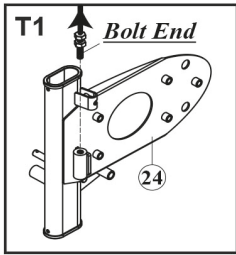

Cable Routing Overview

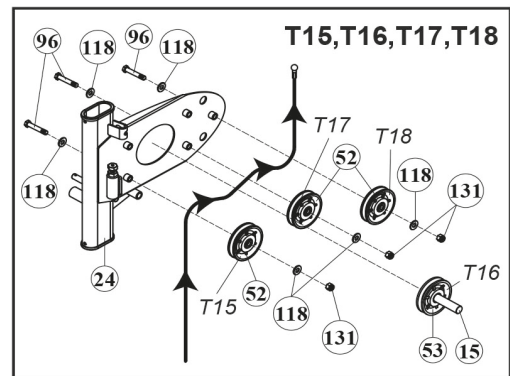
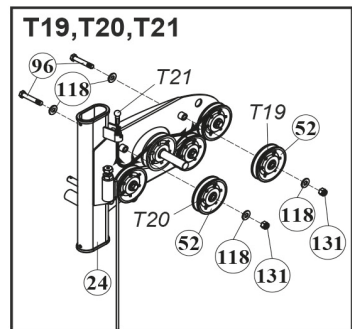
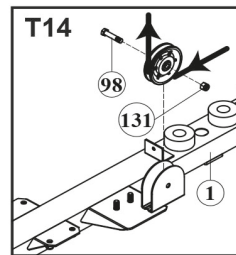
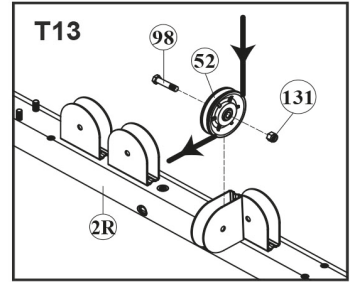
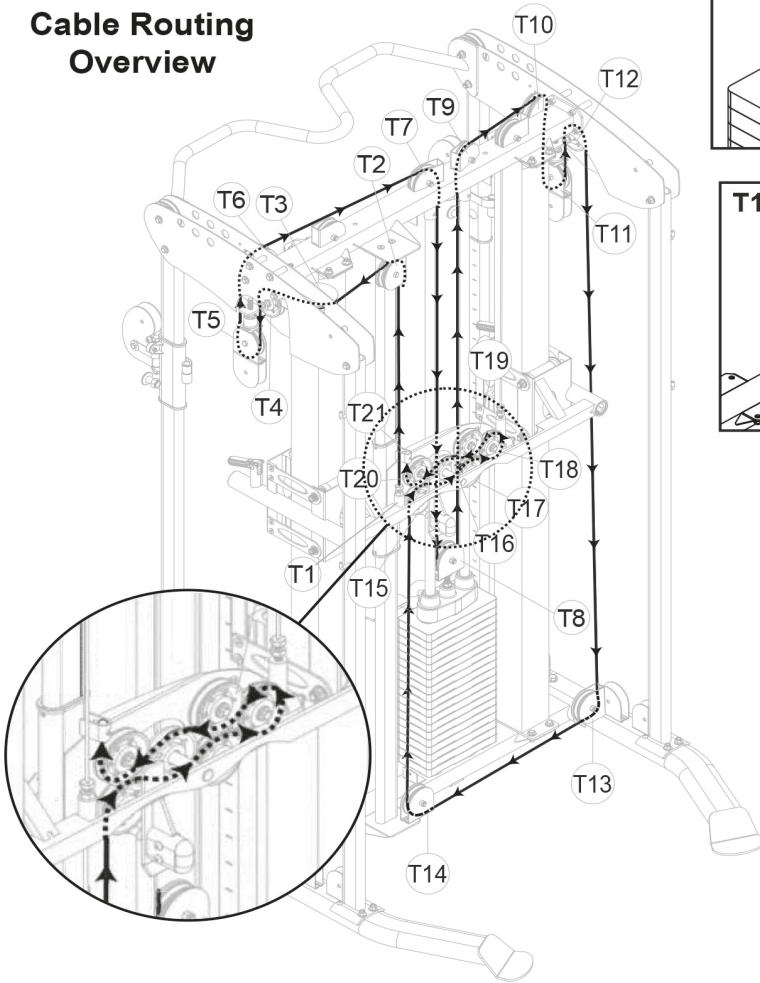

Step 13: Assembly of the Low Cable and Pulleys

NOTICE

- + Before proceeding with the cable routing, carefully study the cable routing overview beginning with L1.
 - + Route the cable while simultaneously assembling the pulleys as you go.
 - + The following steps show the assembly procedure for the right side of the machine. The steps must be repeated for the left side as well.
1. Route the low cable (55) under one 90mm pulley (52) and attach the pulley (52) to the rotating pulley holder (18) with one bolt (98) and one nylon nut (131). Make sure the ball end of the cable is facing the outside of the machine like shown [L1].
 2. Route the cable (55) over the 90mm pulley (52) mounted in the right top panel (22R) [L2].
 3. Route the cable (55) under the two bolts [fig. 2] and around one 90mm pulley (52) and attach the pulley (52) to the right top panel (22R) with one bolt (95) and one nylon nut (131) [L3].
 4. Route the cable (55) down into and through the rear right upright frame (9R) [fig. 1].
 5. Route the cable (55) under one 90mm pulley (52) and attach the pulley (52) to the rear right upright frame (9R) with one bolt (98) and nylon nut (131) [L4].
 6. Route the cable (55) under one 90mm pulley (52) and attach the pulley (52) to the right base leg (2R) with one bolt (98) and one nylon nut (131) [L5].
 7. Route the cable (55) over one 90mm pulley (52) and attach the pulley (52) to the lower part of the double pulley block (36) with one bolt (98) and one nylon nut (131) [L6].
 8. Route the cable (55) under two 90mm pulleys (52) and attach the pulleys (52) to the right base leg (2R) with one bolt (98) and one nylon nut (131) each [L7, L8].
 9. Attach the bolt end of the cable (55) to the bolt holder on the right pulley height adjuster (19R) [L9].
 10. Repeat the steps 1 to 9 on the left side with the second low cable (55).

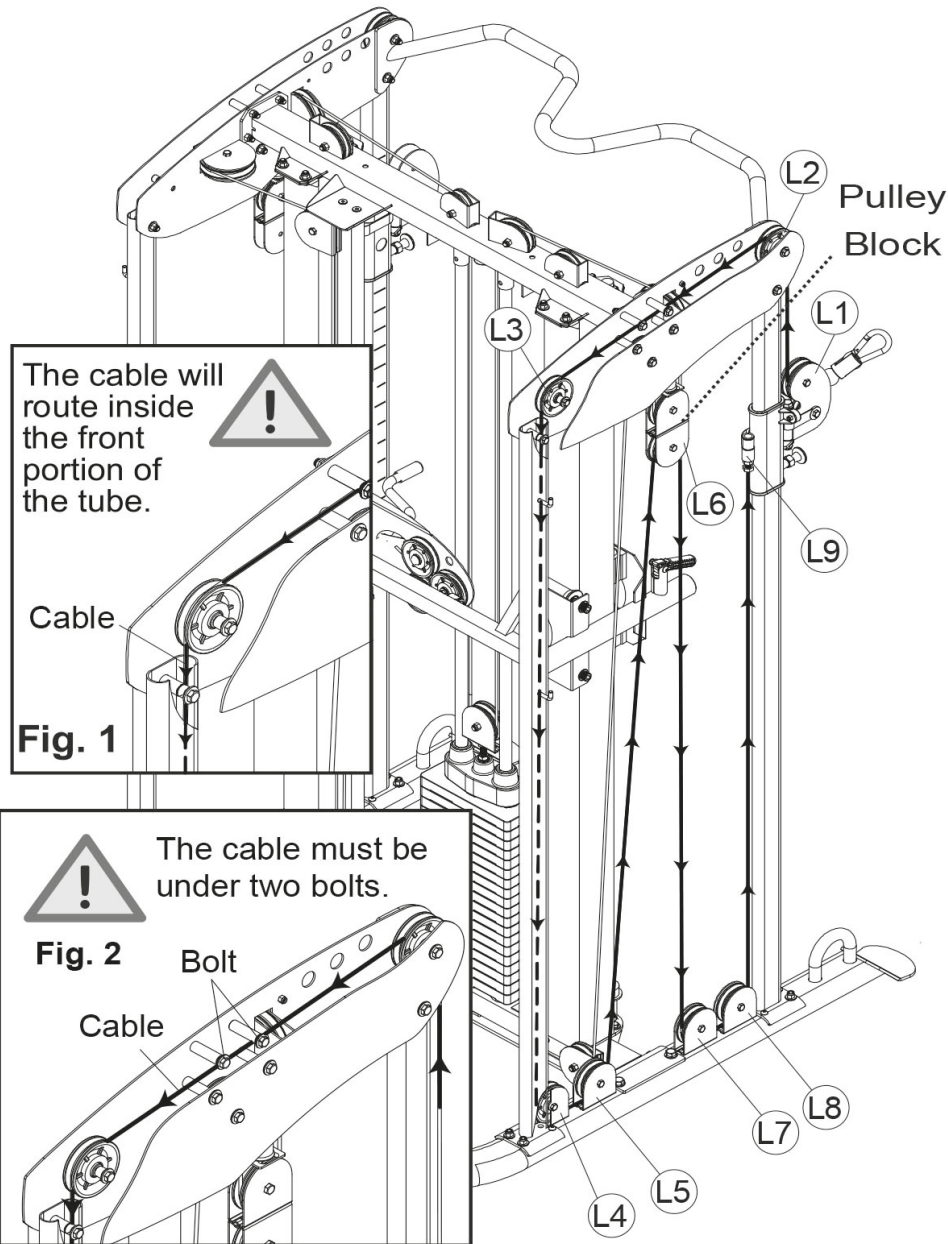
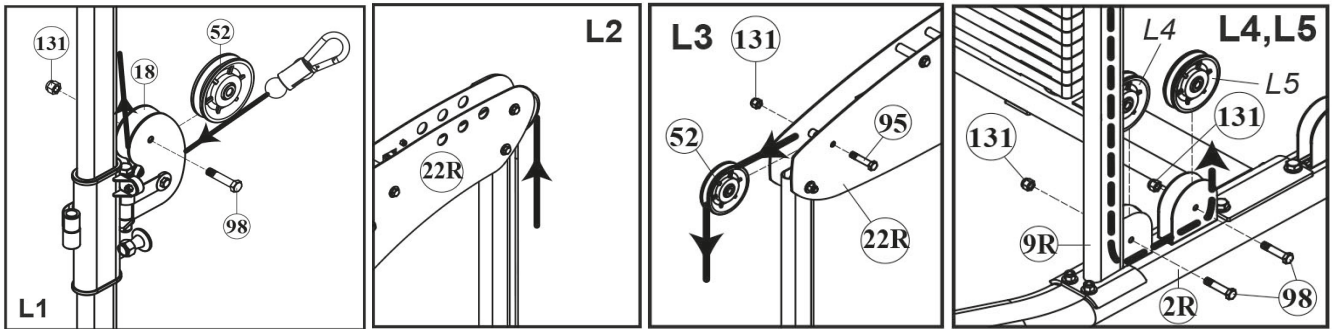

The cable will route inside the front portion of the tube.

Cable

Fig. 1

The cable must be under two bolts.

Fig. 2 Bolt

Cable

L6 **36**

98 **131**

52

Pulley Block

L7, L8 **L8** **7R**

L7

131

2R **98**

19R

Bolt End

L9

Step 14: Assembly of the Weight Shroud

Attach the right and left weight shrouds (12R & 12L) to the top frame (13) and base frame (1) with two screws (107) and two washers (119) per weight shroud.

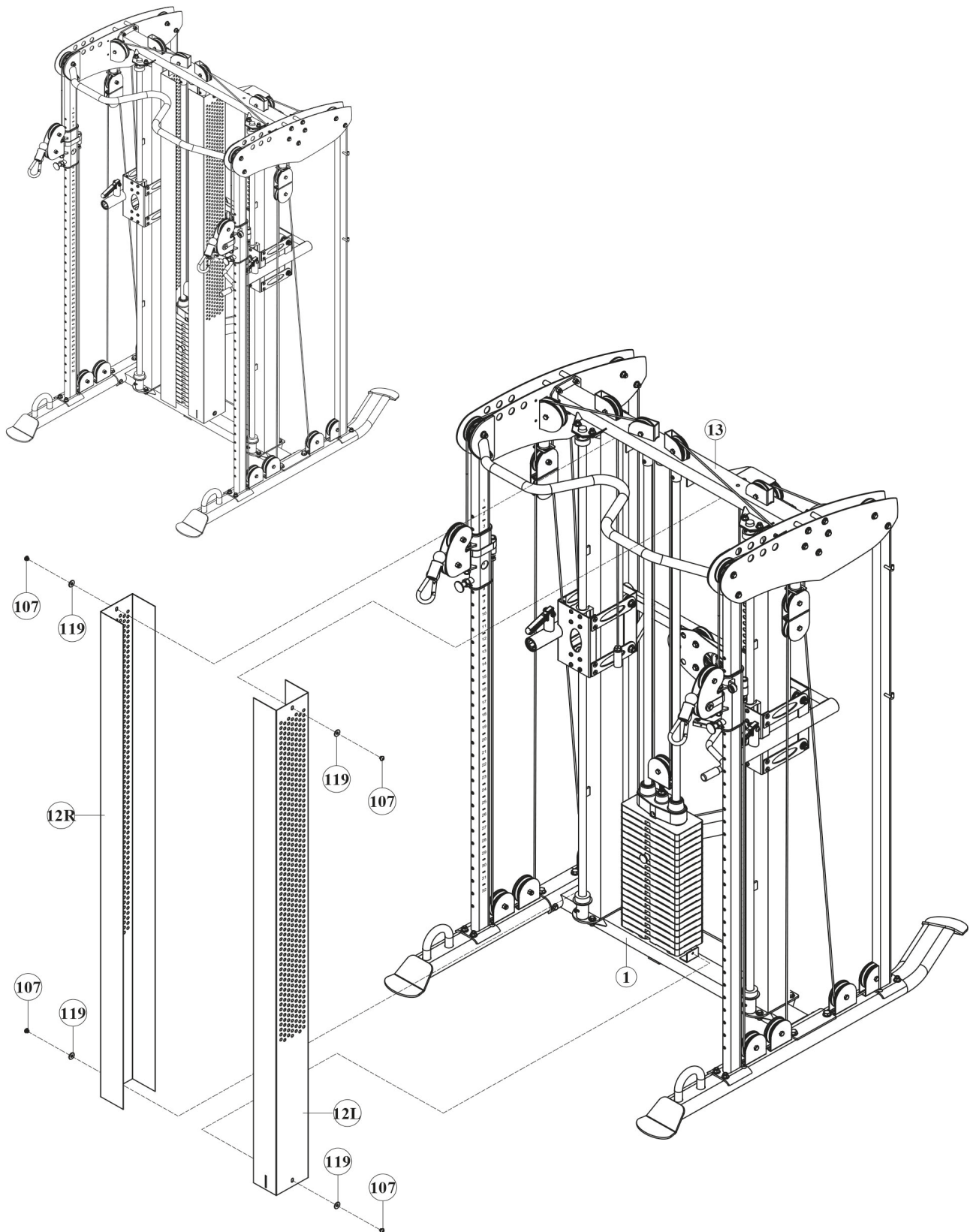

Step 15: Assembly of the Panel

Attach the panel (16) to the right and left top panel (22R & 23L) with four bolts (148) and four washers (125).

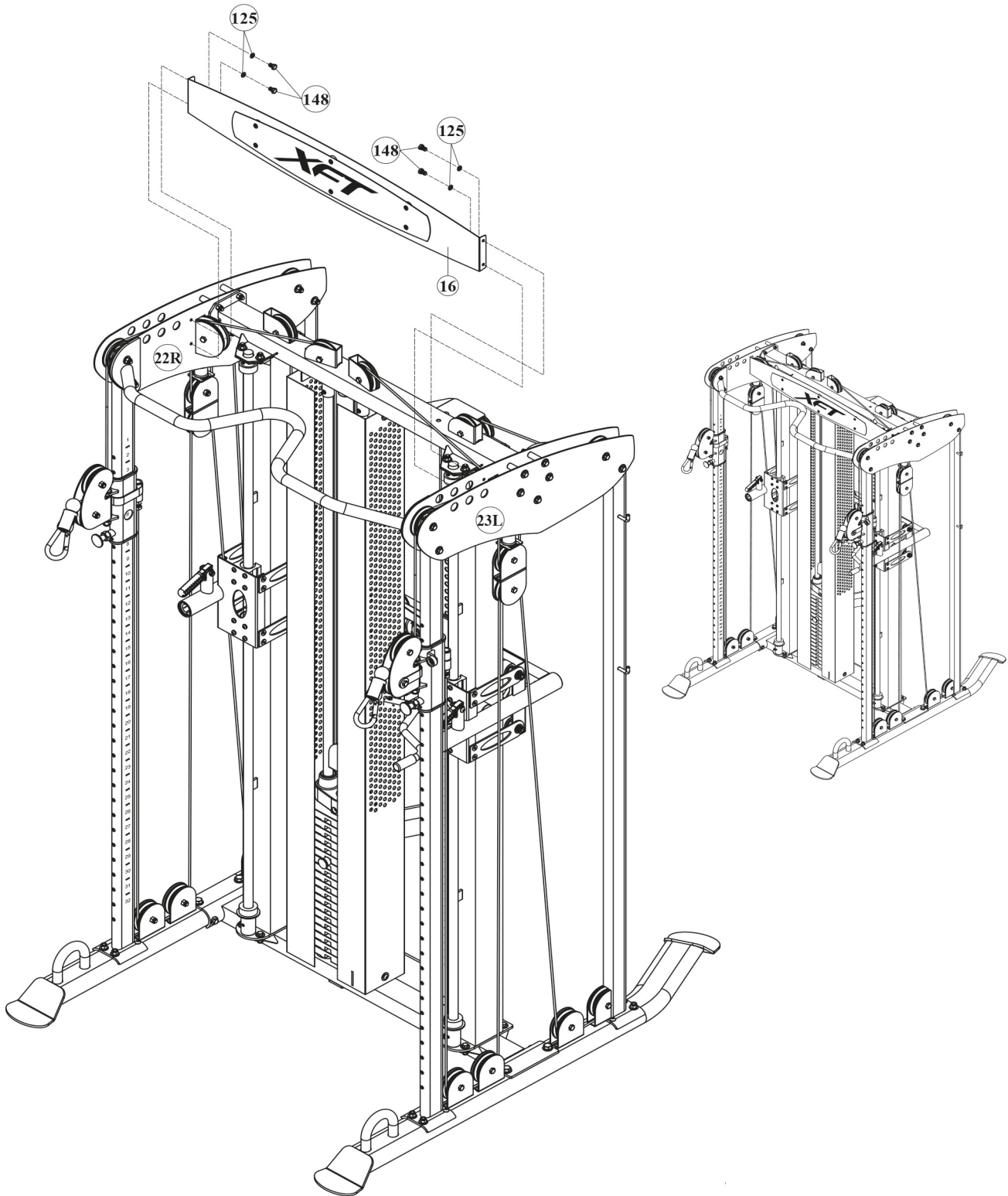

Step 16: Assembly of the Press Bar

Attach the press bar (27) and two 25mm x 1100L solid linear guide rods (31) to the connector frame (15) with two 48mm rubber cushions (75), two steel collars (78) and two screws (115) at the back and two 61mm rubber cushions (75A), two screws (115) and two screws (116) at the front.

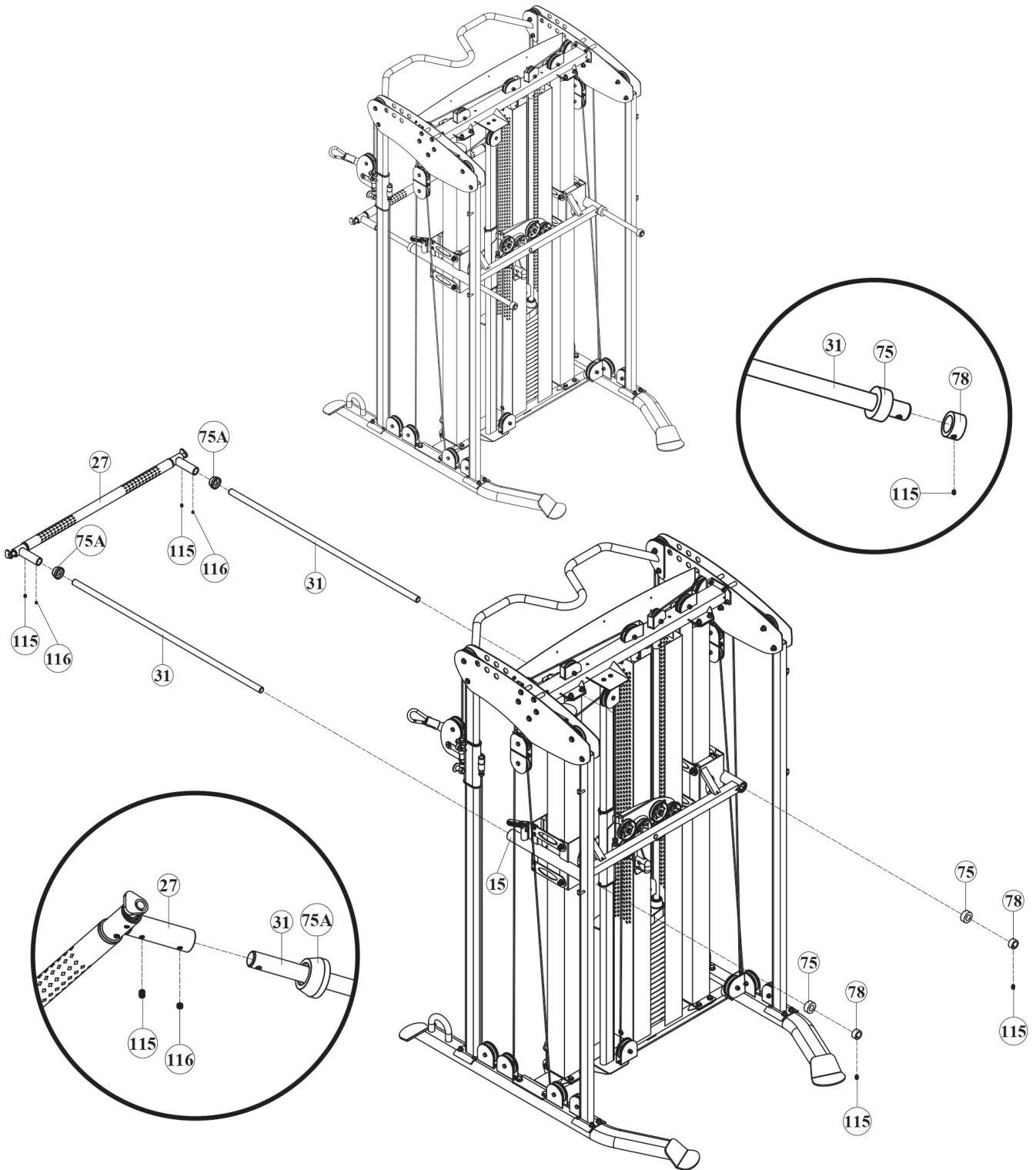

Product Functions

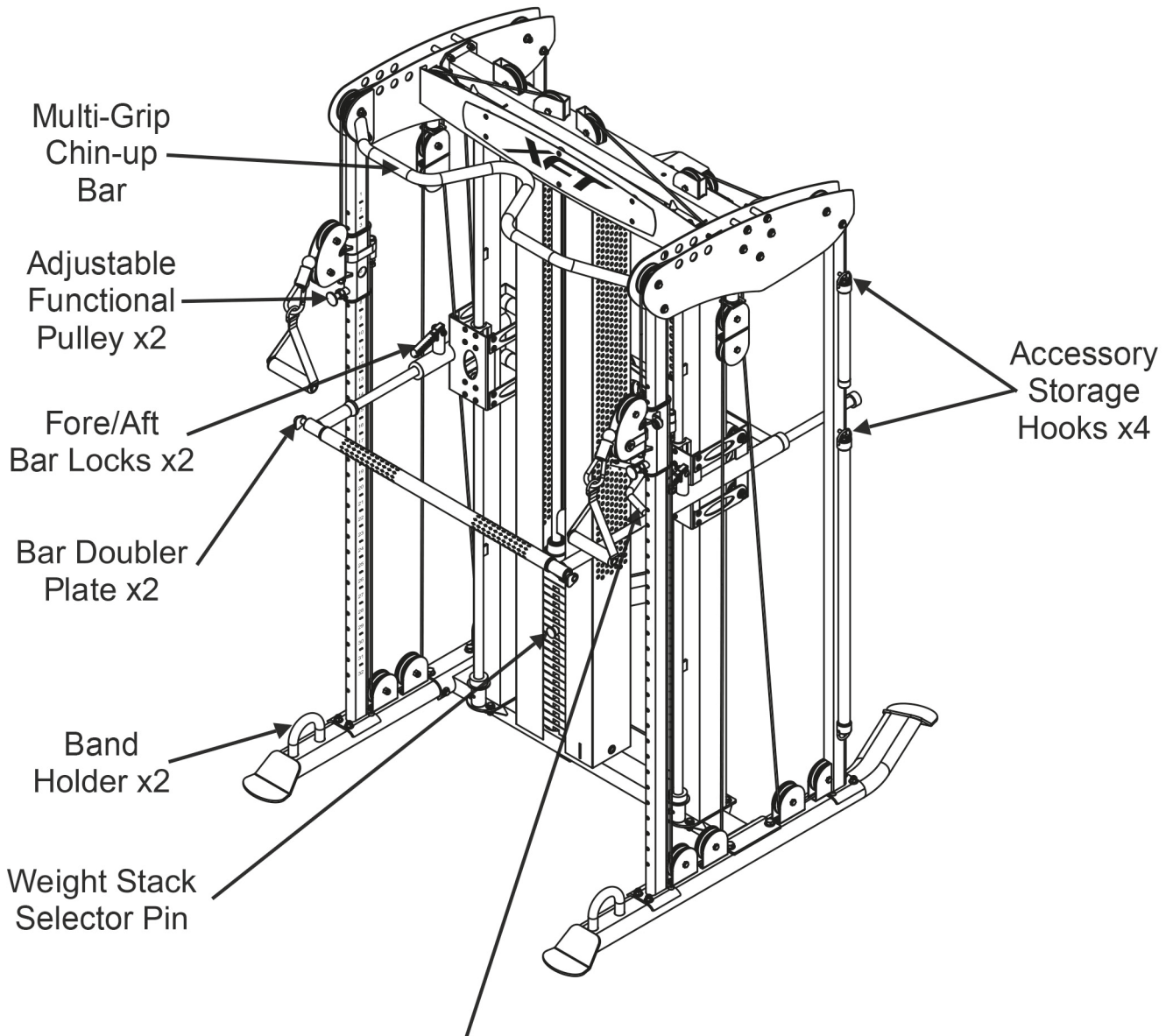

Bar Vertical Range of Motion Adjustment Lever (Top View)

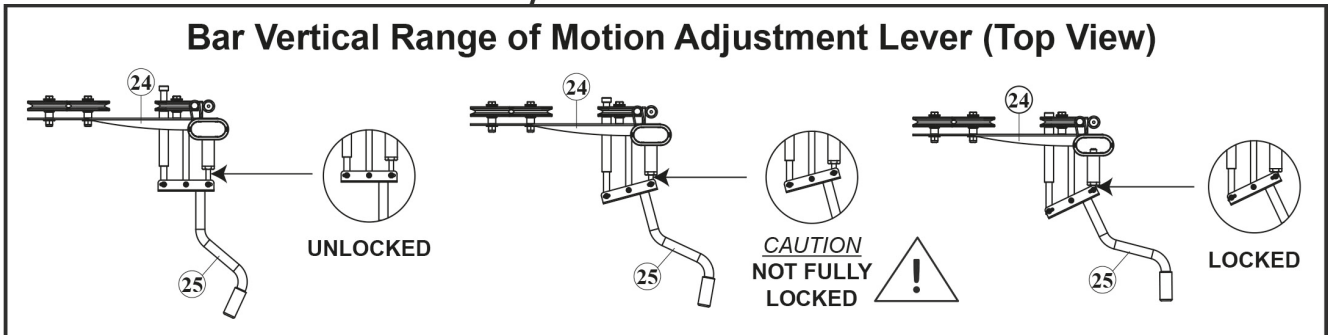

3.1 General Instructions



WARNING

- + The storage location should be chosen so that improper use by third parties or children can be prevented.
- + If your equipment does not have transportation wheels, the equipment must be disassembled before transportation.



ATTENTION

- + Make sure that the equipment is protected from moisture, dust and dirt in the selected storage location. The storage location should be dry and well ventilated and have a constant ambient temperature between 10°C and 35°C.

4.1 General Instructions



WARNING

- + Do not make any improper changes to the equipment.



CAUTION

- + Damaged or worn components may affect your safety and the life of the equipment. Therefore, immediately replace damaged or worn components. In such a case, contact the contract partner. The equipment must not be used until it has been repaired. If necessary, use only original spare parts.

ATTENTION

- + In addition to the instructions and recommendations for maintenance and care given here, additional service and/or repair work may be necessary; this must only be carried out by authorised service technicians.

4.2 Faults and Fault Diagnosis

The equipment undergoes regular quality controls during production. Nevertheless, faults or malfunctions may occur. Frequently, individual parts are responsible for these disturbances, an exchange is usually sufficient. Please refer to the following overview for the most common errors and how to correct them. If the equipment still does not function properly, contact your contract partner.

Fault	Cause	Solution
Grinding noises	Cables or pulleys do not run smoothly or are damaged	+ Visual inspection of the cable routing or the pulley guide + If damaged, replace the defective part
Weight hanging in the air	Cable tensioned too tight	Readjust cable tension
Cable without tension	Cable too loose	+ Check cable routing + Readjust cable tension
Squeaking & cracking noises	Screw connections loosened or too tight	+ Check or lubricate screw connections* + Check cable routing
Unit wobbles	+ Uneven ground + Loose screw connections	+ Align unit + Tighten screw connections
Heavy draught	+ Weight holders/guide rods too dry + Faulty cable routing	+ Lubricate guide rods* + Check cable routing

* With a grease-free silicone oil or silicone spray.

4.3 Maintenance and Inspection Calendar

To avoid damage from body sweat, the equipment must be cleaned with a damp towel (no solvents!) after each training session.

The following routine tasks must be performed at the specified intervals:

Part	Weekly	Monthly
Cables	C	I
Screw connections		I
Pulleys and cable routing		I
Slide rails/Guide rods		I
Legend: C = clean; I = inspect		

5 DISPOSAL

At the end of its operational life, this equipment cannot be disposed of in normal household waste. Instead, it must be disposed of via an recycling centre. Further information can be obtained from your local authority's recycling service.



The materials can be recycled as per their symbols. Through the reuse, recycling of materials or other forms of recovery of old equipment, you make an important contribution to the protection of the environment.

6 RECOMMENDED ACCESSORIES

To make your training experience even more efficient and pleasant, we recommend that you add suiting accessories to your fitness equipment. For training equipment like smith machines, weight benches or racks this could for example be a **floor mat**, which makes your fitness equipment stand more securely and also protects the floor from sweat but it could be also **additional weights, handles, foot straps** for leg exercises or **triceps ropes**. For some smith machines, there are also optional add-ons such as **leg presses** that make your workout even more intense and comprehensive.

Our range of accessories offers the highest quality and makes training even better. If you would like to find out more about compatible accessories, please go to the detail page of the product in our webshop (the easiest way is to enter the article number in the search field above) and go to the recommended accessories on this page. Of course, you can also contact our customer service: by telephone, e-mail, in one of our branches or via our social media channels. We will be happy to advise you!



floor mat



chest strap



weight block extension



triceps rope

7.1 Serial Number and Model Name

In order to provide you with the best possible service, please have the model name, article number, serial number, exploded drawing and parts list ready. The corresponding contact options can be found in chapter 9 of this operating manual.

NOTICE

The serial number of your equipment is unique. It's located on a white sticker. The exact position of this sticker is shown in the following illustration.

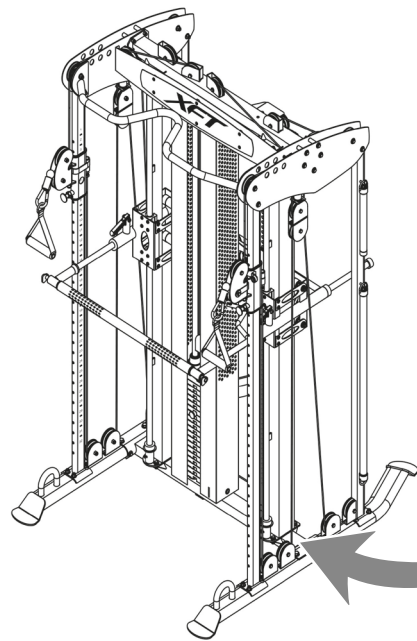

Enter the serial number in the appropriate field.

Serial number:

Brand / Category:

Model Name:

Article Number:

7.2 Parts List

No.	Name	Qty.	No.	Name	Qty.
1	BASE FRAME	1	28	LONG BAR	1
2R	RIGHT BASE LEG	1	29	SPORT BAR	1
3L	LEFT BASE LEG	1	30	SPORT BAR COLLAR	3
4	HOLLOW GUIDE ROD	2	31	25mm X 1100mm SOLID LINEAR GUIDE ROD	2
5	MAIN UPRIGHT FRAME	2	32	1" X 977L ALUMINUM BAR	1
6	UPRIGHT FRAME	1	33	1" X 900L FOAM GRIP	1
7R	FRONT RIGHT UPRIGHT FRAME	1	34	1" X 295L FOAM GRIP	1
8L	FRONT LEFT UPRIGHT FRAME	1	35	1" X 60L ALUMINUM FOAM GRIP	1
9R	REAR RIGHT UPRIGHT FRAME	1	36	DOUBLE PULLEY BLOCK	2
10L	REAR LEFT UPRIGHT FRAME	1	37	PULLEY BLOCK	1
11	25mm x 1945 mm SOLID LINEAR GUIDE ROD	2	38	TOP PLATE	1
12R	RIGHT WEIGHT SHROUD	1	39	WEIGHT PLATE (150LBS)	14
12L	LEFT WEIGHT SHROUD	1	39	WEIGHT PLATE (200LBS)	19
13	TOP FRAME	1	40	SELECTOR ROD	1
14	CHIN-UP BAR	1	41	ANKLE STRAP	1
15	CONNECTOR FRAME	1	42	SINGLE HANDLE	2
16	PANEL	1	43	CHAIN	2
16A	LOGO PANEL	1	44	STEEL PLATE MAIN	6
17	TOP GUIDE ROD HOLDER	1	44A	STEEL PLATE A	1
18	ROTATING PULLEY HOLDER	2	44B	STEEL PLATE B	1
19R	RIGHT PULLEY HEIGHT ADJUSTER	1	45R	RIGHT AXLE ASSEMBLY	1
20L	LEFT PULLEY HEIGHT ADJUSTER	1	46L	LEFT AXLE ASSEMBLY	1
21	AXLE CONNECTOR	2	47	TOP CW ASSEMBLY	2
22R	RIGHT TOP PANEL	1	48	BOTTOM CW ASSEMBLY	2
23L	LEFT TOP PANEL	1	49	CW COVER	8
24	ADJUSTER FRAME	1	50	38mm CW	8
25	ADJUSTMENT LEVER	1	51	114mm PULLEY	3
26	STACK SPACER	2	52	90mm PULLEY	35
27	PRESS BAR	1	53	90mm PULLEY (NO INSERT)	1
			54	WEIGHT CABLE	2

55	LOW CABLE	2	88	WASHER FOR BRACKET	2
56	TOP CABLE	1	89	R40 SPRING CLIP	4
57	PLASTIC BUSHING	6	90	1/2" STOPPER	2
58	ELASTIC BAND	2	91	M12 X 170L SCREW	4
59	25mm LINEAR BEARING CARTRIDGE	4	92	1/2" X 4-1/4" HEX BOLT	2
60	SELECTOR PIN	1	93	1/2" X 1" HEX THREADED BOLT	4
61	POP PIN	2	94	3/8" X 3-1/8" HEX BOLT	12
62	CLUTCH LEVER	2	95	3/8" X 3" HEX BOLT	6
63	LONG ROLLER	4	96	3/8" X 2-1/4" HEX BOLT	5
64	25mm HOLLOW BUSHING	4	97	3/8" X 2" HEX BOLT	2
65	ROLLER	4	98	3/8" X 1-3/4" HEX BOLT	25
66	AXLE	1	99	WHEEL BRACKET FOR BOX	16
67	ROLLER	4	100	3/8" X 1" HEX THREADED BOLT	22
68	HOOK	4	102	5/16" X 1-3/4" HEX BOLT	2
69	42mm SPRING	2	103	TOP PLATE BOLT	1
70	36mm SPRING	1	104	3/8" X 1" SUNKEN HEAD BOLT	8
71	91mm PIN BOLT	1	105	3/8" X 3/4" ROUND SCREW	1
72	PLASTIC GUIDE ROD HOLDER	2	106	5/16" X 5/8" ROUND SCREW	2
73	HOLDER	2	107	5/16" X 1/4" ROUND SCREW	4
74	64mm RUBBER CUSHION	2	108	5/16" X 1-1/4" SUNKEN HEAD BOLT	1
75	48mm RUBBER CUSHION	6	109	M6 X 12L ROUND SCREW	19
75A	61mm RUBBER CUSHION	2	110	5/16" X 1-1/4" SCREW	1
76	ALUMINUM SPACER	1	111	M8 X 40L SCREW	2
77	STOPPER	1	112	M4 X 25L SCREW	3
78	STEEL COLLAR	2	113	M6 X 20L SUNKEN HEAD BOLT	32
79	D25mm MAGNET	2	114	5/16" X 5/8" INNER HEX SCREW	2
81	1/2" BUSHING	4	115	5/16" X 3/8" INNER HEX SCREW	4
82	6001ZZ BEARING	14	116	5/16" X 1/4" INNER HEX SCREW	10
83	3/8" RUBBER STOPPER	2	117	1/2" LARGER WASHER	4
84	1" STEEL STOPPER	2	118	3/8" WASHER	80
85	28mm X 10mm STOPPER	2	119	5/16" WASHER	4
86	28mm X 7.5mm STOPPER	6	120	1/2" SPRING WASHER	6
87	NUT FOR ADJUSTER FRAME	1	121	3/8" SPRING WASHER	4

122	5/16" X 1/2" SUNKEN HEAD BOLT	16
123	M12 SPRING WASHER	8
124	M6 SPRING WASHER	16
125	M6 WASHER	5
126	M4 WASHER	6
127	C RING	3
128	5/16" NUT	1
129	M12 NYLON NUT	4
130	1/2" NYLON NUT	2
131	3/8" NYLON NUT	76
132	5/16" NYLON NUT	3
133	M8 NYLON NUT	2
134	M6 NYLON NUT	2
135	M4 NYLON NUT	3
136	1/2" NUT	3
137	M5 X 6mm INNER HEX SCREW	2

7.3 Exploded Drawing

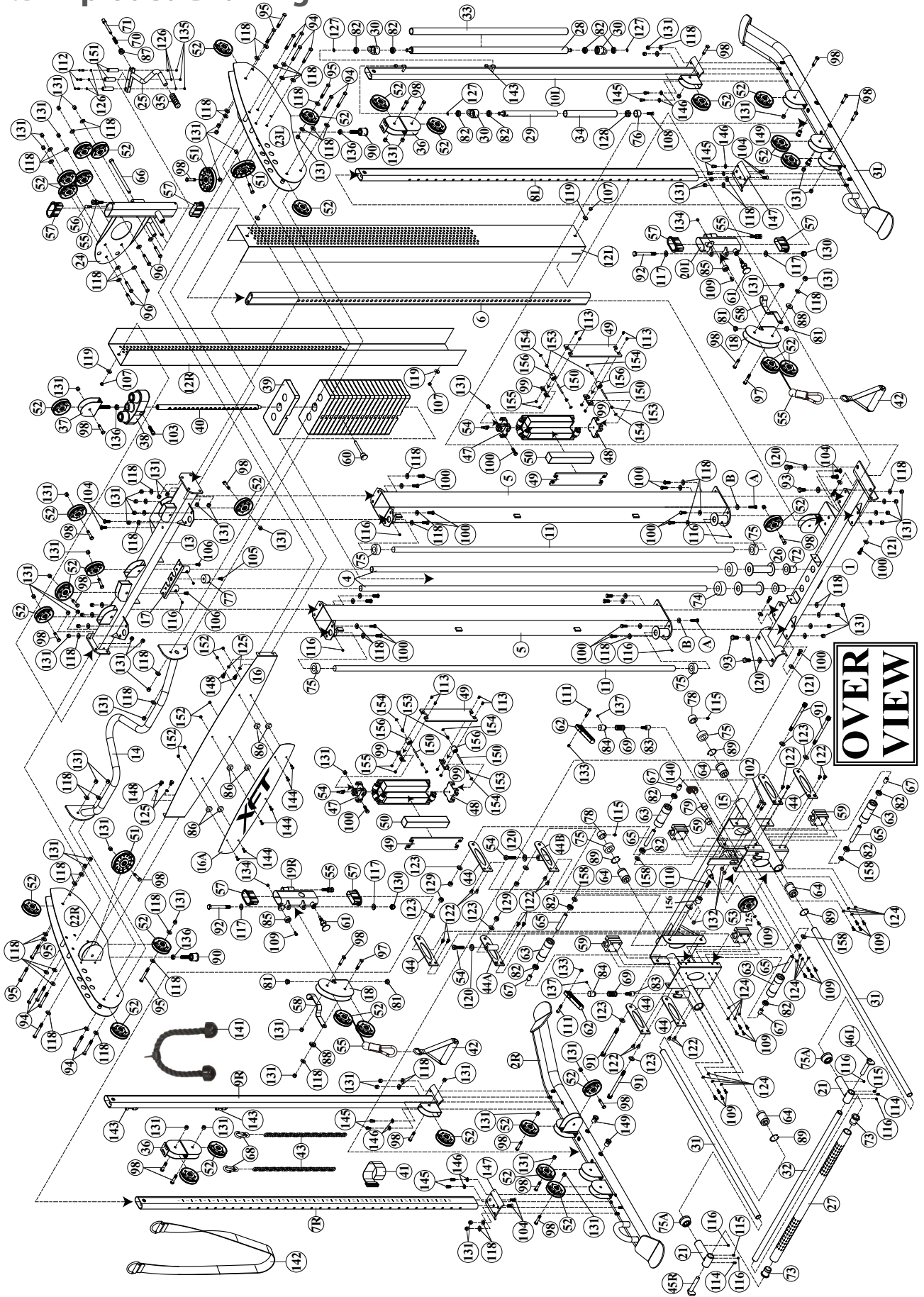

Training equipment from BodyCraft® is subject to strict quality control. However, if a fitness equipment purchased from us does not work perfectly, we take it very seriously and ask you to contact our customer service as indicated. We are happy to help you by phone via our service hotline.

Error Descriptions

Your fitness equipment is developed for long-term, high-quality training. However, should a problem arise, please first read the operating instructions. For further assistance, please contact your contract partner or call our service hotline. To ensure your problem is solved as quickly as possible, please describe the defect as exactly as possible.

In addition to the statutory warranty, we provide a warranty for every fitness equipment purchased from us according to the following provisions.

Your statutory rights are not affected.

Warranty

The warranty is the first/original buyer and/or any person who received a newly purchased product as a gift from the original buyer.

Warranty period

The warranty periods, shown on our web shop, begin on delivery of the fitness equipment. The respective warranty periods for your equipment can be found on its product website.

Repair Costs

According to our choice, there will either be a repair, a replacement of individual damaged parts or a complete replacement. Spare parts, that have to be mounted while assembling the equipment, have to be replaced by the warranty personally and are not a part of repair. After the expiration of the warranty period for repair costs, a pure parts warranty applies, which does not include the repair, installation and delivery costs.

The terms of use are defined as follows:

- + Home use: solely for private use in private households up to 3 hours per day
- + Semi-professional use: up to 6 hours per day (e. g. rehabilitation centres, hotels, clubs, company gyms)
- + Professional use: more than 6 hours per day (e. g. commercial gyms)

Warranty Service

Within the warranty period, equipment which develops faults as a result of material or manufacturing defects, will be repaired or replaced at our discretion. Ownership of equipment or parts of equipment which have been replaced is transferred to us. The warranty period is not extended nor does a new warranty period begin following repair or replacement under the warranty.

Warranty Conditions

For the warranty to be valid, the following steps must be taken:

Please contact our customer service by email or phone. If the product under warranty has to be sent in for repair, the seller bears costs. After expiry of the warranty, the buyer bears the costs of transport and insurance. If the fault is covered by our warranty, you will receive a new or repaired equipment in return.

Warranty claims are invalid in case of damage resulting from:

- + misuse or improper handling
- + environmental influences (moisture, heat, electrical surge, dust, etc.)
- + failure to follow the current safety measures for the equipment
- + failure to follow the operating instructions
- + use of force (e. g. hitting, kicking, falling)
- + interventions which were not carried out by one of our authorized service centres
- + unauthorised repair attempts

Proof of Purchase and Serial Number

Please make sure that you are able to provide the appropriate receipt when claiming on your warranty. So that we can clearly identify the model of your equipment, and for the purposes of our quality control, you will need to give the serial number of your equipment, when contacting the service team. Where possible please have your serial number and your customer number ready when you call our service hotline. It will help us to deal with your request swiftly.



















If you cannot find the serial number on your fitness equipment, our service team is at your disposal to offer further information.















Service outside of the Warranty Period

We are also happy to issue an individual cost estimate if there is a problem with your fitness equipment after the warranty has expired, or in cases which do not fall under the terms of the warranty, e. g. normal wear and tear. Please contact our customer service team to find a quick and cost-effective solution to your problem. In such a case you will be responsible for the delivery costs.

Communication

Many problems can be solved just by speaking to us as your specialist supplier. We know how important it is to you as a user of the fitness equipment to have problems solved quickly and simply, so you can enjoy working out with minimal interruption. For that reason, we also want to resolve your queries quickly and in a straightforward manner. Thus, please always keep your customer number and the serial number of the faulty equipment handy.

DE	DK	FR
<p>TECHNIK</p> <p> +49 4621 4210-900</p> <p> +49 4621 4210-698</p> <p> technik@sport-tiedje.de</p> <p> Öffnungszeiten entnehmen Sie unserer Homepage.</p> <p>SERVICE</p> <p> 0800 20 20277 (kostenlos)</p> <p> info@sport-tiedje.de</p> <p> Öffnungszeiten entnehmen Sie unserer Homepage.</p>	<p>TEKNIK OG SERVICE</p> <p> 80 90 16 50</p> <p>+49 4621 4210-945</p> <p> info@fitshop.dk</p> <p> Åbningstider kan findes på hjemmesiden.</p>	<p>TECHNIQUE & SERVICE</p> <p> +33 (0) 172 770033</p> <p>+49 4621 4210-933</p> <p> service-france@fitshop.fr</p> <p> Vous trouverez les heures d'ouverture sur notre site Internet.</p>
	PL	BE
	<p>TECHNIKA I SERWIS</p> <p> 22 307 43 21</p> <p>+49 4621 42 10-948</p> <p> info@fitshop.pl</p> <p> Godziny otwarcia można znaleźć na stronie głównej.</p>	<p>TECHNIQUE & SERVICE</p> <p> 02 732 46 77</p> <p>+49 4621 42 10-932</p> <p> info@fitshop.be</p> <p> Vous trouverez les heures d'ouverture sur notre site Internet.</p>

UK	NL	INT
<p>CUSTOMER CARE</p> <p> +44 141 737 2249</p> <p> customercare@powerhouse-fitness.co.uk</p> <p> You can find the opening hours on our homepage.</p>	<p>TECHNISCHE DIENST & SERVICE</p> <p> +31 172 619961</p> <p> info@fitshop.nl</p> <p> De openingstijden vindt u op onze homepage.</p>	<p>TECHNICAL SUPPORT & SERVICE</p> <p> +49 4621 4210-944</p> <p> service-int@sport-tiedje.de</p> <p> You can find the opening hours on our homepage.</p>
	AT	CH
	<p>TECHNIK & SERVICE</p> <p> 0800 20 20277 (Freecall)</p> <p>+49 4621 42 10-0</p> <p> info@sport-tiedje.at</p> <p> Öffnungszeiten entnehmen Sie unserer Homepage.</p>	<p>TECHNIK & SERVICE</p> <p> 0800 202 027</p> <p>+49 4621 42 10-0</p> <p> info@sport-tiedje.ch</p> <p> Öffnungszeiten entnehmen Sie unserer Homepage.</p>

Please find a detailed overview including address and opening hours for all stores of the Sport-Tiedje Group in Germany and abroad on the following website:

www.sport-tiedje.com/en/stores

WE LIVE FITNESS

WEBSHOP AND SOCIAL MEDIA

Sport-Tiedje is Europe's largest specialist store for home fitness equipment with currently over 70 stores and one of the world's most renowned online mail order companies for fitness equipment. Private customers order via the 25 web shops in the respective national language or have their desired equipment assembled on site. In addition, the company supplies fitness studios, hotels, sports clubs, companies and physio practices with professional equipment for endurance and strength training.

Sport-Tiedje offers a wide range of fitness equipment from renowned manufacturers, high-quality in-house developments and comprehensive services, such as a build-up service and sports scientific advice before and after the purchase. The company employs numerous sports scientists, fitness trainers and competitive athletes.

Visit us also on our social media platforms or our blog!



www.sport-tiedje.co.uk
www.sport-tiedje.de/blog



www.facebook.com/SportTiedje



www.instagram.com/sporttiedje



www.youtube.com/user/sporttiedje

TAURUS

 cardiostrong

BODYCRAFT

 cardiojump

 **DUKEFITNESS**

DARWIN

BODYCRAFT